

100mΩ Power Distribution Switches

● Features

- 100mΩ Typ. High-Side NMOSFET
- Guaranteed 1.1A Continuous Current
- 1.5A Current Limit
- Small SOT23-5 Package Minimizes Board Space
- Soft Start
- Thermal Protection
- Low 23μA Supply Current
- Wide Input Voltage Range: 2.2V ~ 6V

● General Description

The FS9006 is an integrated 100mΩ power switch for self-powered and bus-powered Universal Series Bus (USB) applications. A built-in charge pump is used to drive the N-channel NMOSFET that is free of parasitic body diode to eliminate any reversed current flow across the switch when it is powered off. Its low quiescent supply current (23μA) and small package (SOT23-5) is particularly suitable in battery-powered portable equipment.

Several protection functions include soft start to limit inrush current during plug-in, current limiting at 1.5A to meet USB power requirement, and thermal shutdown to protect damage under over current conditions.

● Package Information

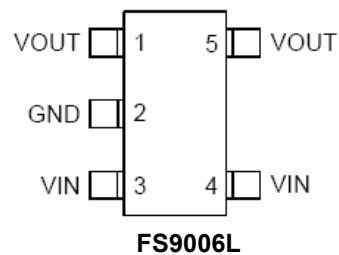
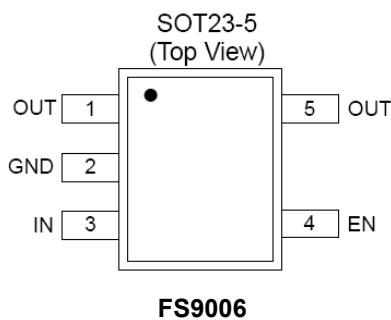

● Pin Description

Pin Name	Pin Function
OUT	Power output. A discharge FET is connected to the OUT pin when the device is disabled by EN pin or the input voltage is below UVLO threshold.
GND	Ground Pin
EN	Enable input (Active High)
IN	Power supply input. Must be closely decoupled to GND pins with a 1μF or greater ceramic capacitor.

● Functional Block Diagram

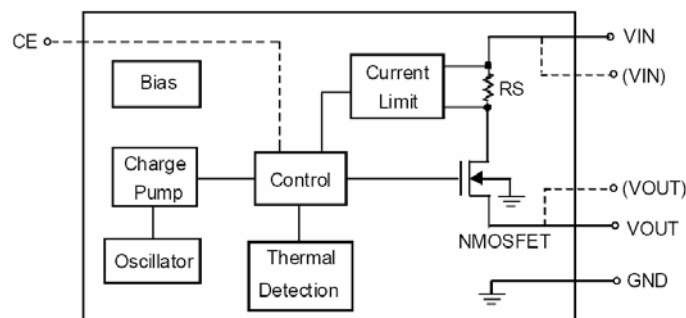

FS9006/L

● Absolute Maximum Ratings

Parameter	Symbol	Limit	Unit
Input Voltage	Vin	-0.3 to 7.0	V
Output Current	Iout	1500	mA
Output Voltage	Vout	Vss-0.3 to VIN +0.3	V
Power Dissipation (Tamb = 25°C)	SOT23-5	300	mW
Operating Temperature	Topr	40 to +125	°C
Storage Temperature	Tstg	65 to +150	°C

● Electrical Characteristics

Vin=Vout+1V, Ta=25°C, Cin=1uF,CL=1uF, unless otherwise sepcified.

Parameter	Symbol	Conditions	Min	Typ	Max	Unit
Output Voltage	VOUT(E)	IOUT = 40mA VIN=VOUT (T)+1V	0.98 × VOUT (T)	VOUT (T)	1.02 × VOUT (T)	V
Maximum Output Current	IOUT max	RL = 2Ω	1.1	1.5	2.0	A
Load Regulation	Δ VOUT	VIN = VOUT+1V 1mA ≤ IOUT ≤ 150mA	--	20	50	mV
Dropout Voltage	Vdrop	IOUT = 150mA	--	100	150	mV
Supply Current	ISS	VIN = VOUT + 1V	--	20	40	uA
Line Regulation	Δ VOUT/ (Δ VIN·VOUT)	IOUT = 40mA VOUT + 1V ≤ VIN ≤ 6V	--	0.2	0.3	%V
Input Voltage	VIN	--	--	--	7	v
Output Voltage Temperature Characteristics	Δ VOUT/ (Δ VIN·VOUT)	IOUT = 40mA -40°C ≤ Ta ≤ 85°C	--	± 100	--	ppm /°C

Note:

1. Vout (T) = Specified output Voltage.
2. Vout (E) = Effective output Voltage (i.e. the output voltage when "Vout (T)+1.0V" is provided at the VIN pin while maintaining a certain Iout value)
3. Vdrop = { VIN1 (note5) - VOUT1 (note4) }
4. Vout1 = A voltage equal to 98% of the output voltage whenever an amply stabilized Iout (Vout (T) +1.0V) is input.
5. VIN1 = The input voltage when Vout = VOUT1

FS9006/L

- **Typical Performance Characteristics** ($T_J = 25^\circ\text{C}$ Noted)

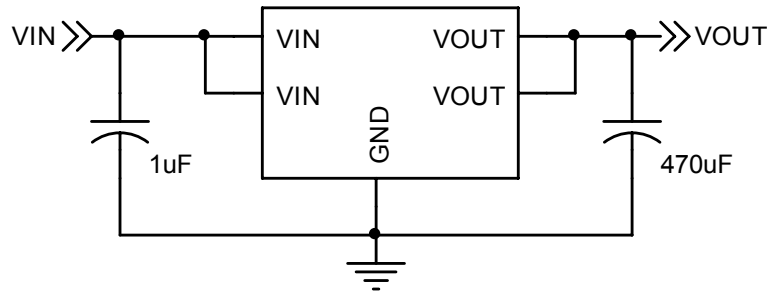

C1 and C2 are Tantalum capacitors

- **Typical Performance Characteristics**

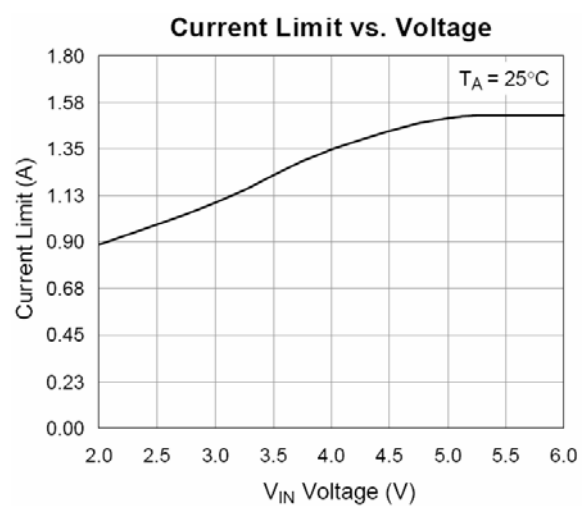
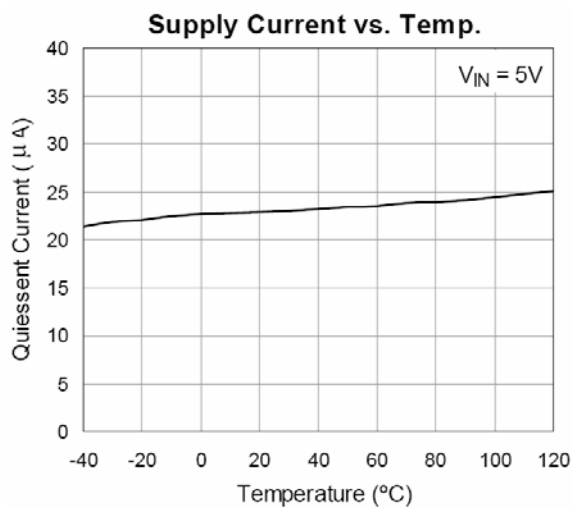
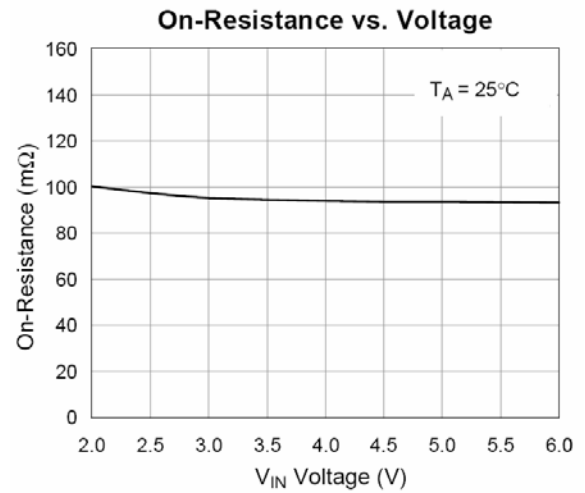
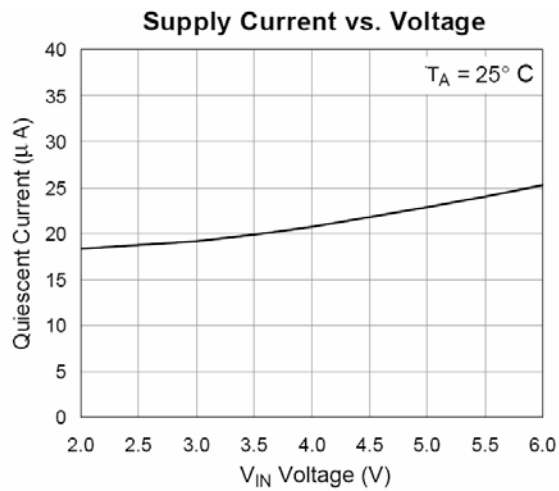

FS9006/L

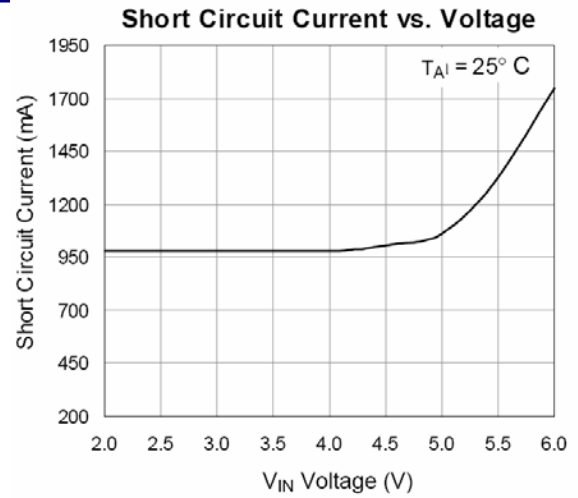
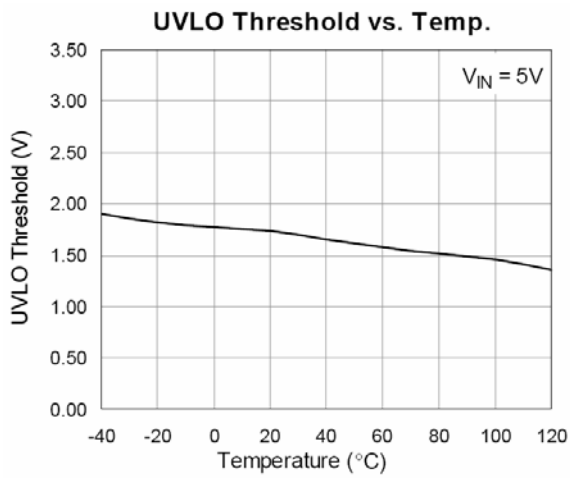

Package Information

SOT-23-5L PACKAGE OUTLINE DIMENSIONS

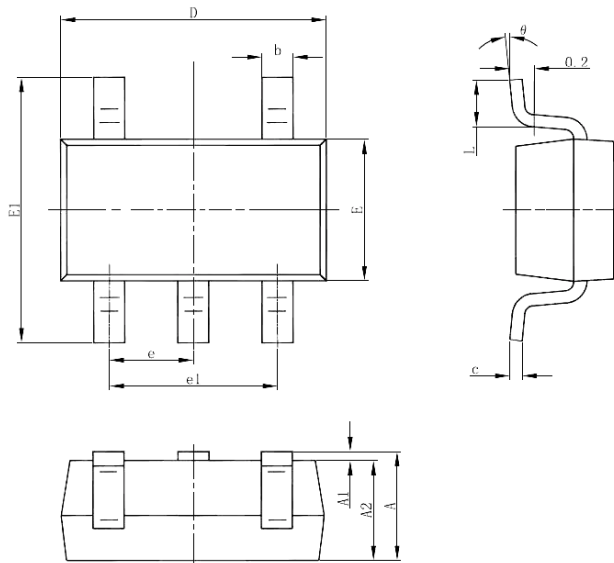

Symbol	Dimensions In Millimeters		Dimensions In Inches	
	Min	Max	Min	Max
A	1.050	1.250	0.041	0.049
A1	0.000	0.100	0.000	0.004
A2	1.050	1.150	0.041	0.045
b	0.300	0.500	0.012	0.020
c	0.100	0.200	0.004	0.008
D	2.820	3.020	0.111	0.119
E	1.500	1.700	0.059	0.067
E1	2.650	2.950	0.104	0.116
e	0.950(BSC)		0.037(BSC)	
e1	1.800	2.000	0.071	0.079
L	0.300	0.600	0.012	0.024
θ	0°	8°	0°	8°