

90mΩ Adjustable Current Limited Power Switches

● Features

- Compliant to USB Specifications
 - Integrated 110mΩ Power MOSFET
 - Low Supply Current
 - 25uA Typical at Switch On State
 - 1uA Typical at Switch Off State
 - Wide Input Voltage Range: 2.4V to 5.5V
 - Fast Transient Response: <2us
 - Reverse Current Flow Blocking
 - Thermal Shutdown Protection
 - Hot Plug-In Application (Soft-Start)
 - Available in a 5-Pin SOT23-5 Package
- Battery-Charger Circuits
 - Personal Communication Devices
 - USB Bus/Self Powered Hubs
 - USB Peripherals
 - Notebook Computers

● General Description

The FS9001B is a cost-effective, low voltage, single P-MOSFET load switch, optimized for self-powered and bus-powered Universal Serial Bus (USB) applications. This switch operates with inputs ranging from 2.4V to 5.5V, making it ideal for both 3V and 5V systems. The switch's low RDS(ON), 110mΩ, meets USB voltage drop requirements. The FS9001B is also protected from thermal overload which limits power dissipation and junction temperatures. It can be used to control loads that require up to 1A. Current limit threshold is programmed with a resistor from SET to ground. The quiescent supply current is typically 15uA at switch on state. At switch off state the supply current decreases to less than 1uA.

The FS9001B is available in SOT23-5 package.

● Package Information & Functional Block Diagram

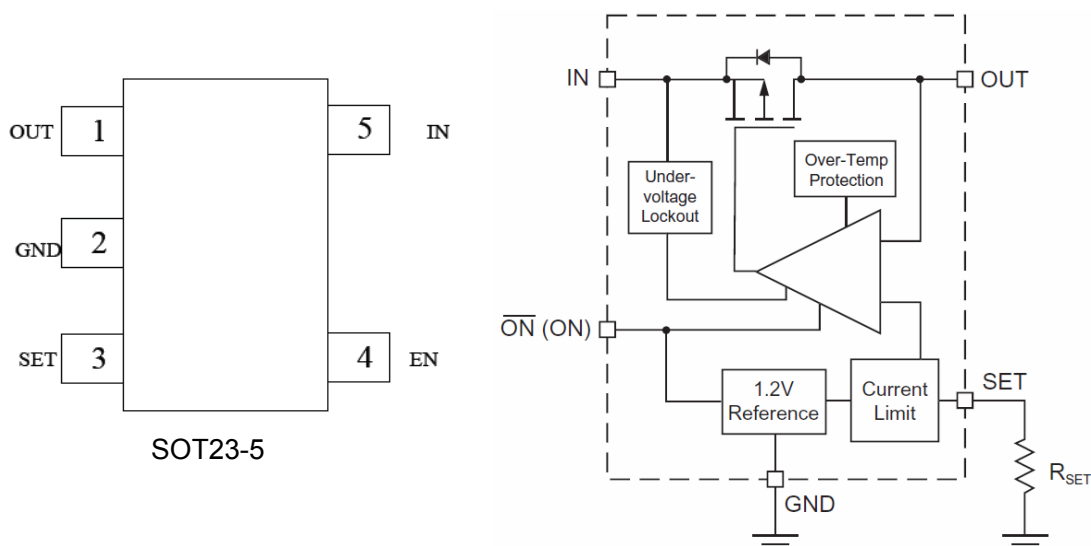

FS9001B

● Absolute Maximum Ratings

Input Supply Voltage-0.3V to 7V
 EN Voltages..... -0.3V to Vin+0.3V
 VSET/VOUT Voltage ..-0.3V to (Vin+0.3V)
 Maxim Continuous Switch Current...1.2A

Operating Temperature Range ... -40°C to +85°C
 Junction Temperature(Note2)125°C
 Storage Temperature Range-65°C to 150°C
 Lead Temperature(Soldering,10s)+300°C

● Electrical Characteristics

V_{IN} = 5V, T_a = 25°C, unless otherwise specified

Parameter		Symbol	Conditions	MIN	TYP	MAX	unit
Input Voltage Range		Vin		2.4		5.5	V
Switch On Resistance		RDS(ON)	Vin=5V		100		mΩ
			Vin=3V		110		
Operation Quiescent Current		IQ	Vin=5V,EN=Active, No load		15	25	μA
Off Supply Current		IQ(OFF)	Vin=5.5V,EN=Inactive			1	μA
Off Switch Current		IQ(SW_OFF)	Vin=5.5V,EN=Inactive			1	μA
Under-voltage Lockout		VUVLO	Vin Increasing		1.8	2.4	V
Under-voltage Lockout Hysteresis		ΔVUVLO	Vin decreasing		0.1		V
Current Limit		ILIM	RSET=9k		TBD		A
EN Threshold	Logic-Low Voltage	VIL	Vin=2.5V to 5.5V			0.8	V
	Logic-High Voltage	VIH	Vin=2.5V to 5.5V	2			V
Output Leakage Current		ILEAK	EN=Inactive, RLOAD=0Ω		0.5	10	μA
Current Limit Response Time		TRESP	Vin=5V		1		μs
Thermal Shutdown Protection		TSD			150		°C
Thermal Shutdown Hysteresis		ΔTSD			20		°C

Note 1: Absolute Maximum Ratings are those values beyond which the life of a device may be impaired.

Note 2: T_J is calculated from the ambient temperature T_A and power dissipation P_D according to the following formula: T_J = T_A + (P_D) x (250°C/W).

Note3: 100% production test at +25°C. Specifications over the temperature range are guaranteed by design and characterization.

FS9001B

- **Typical Performance Characteristics**

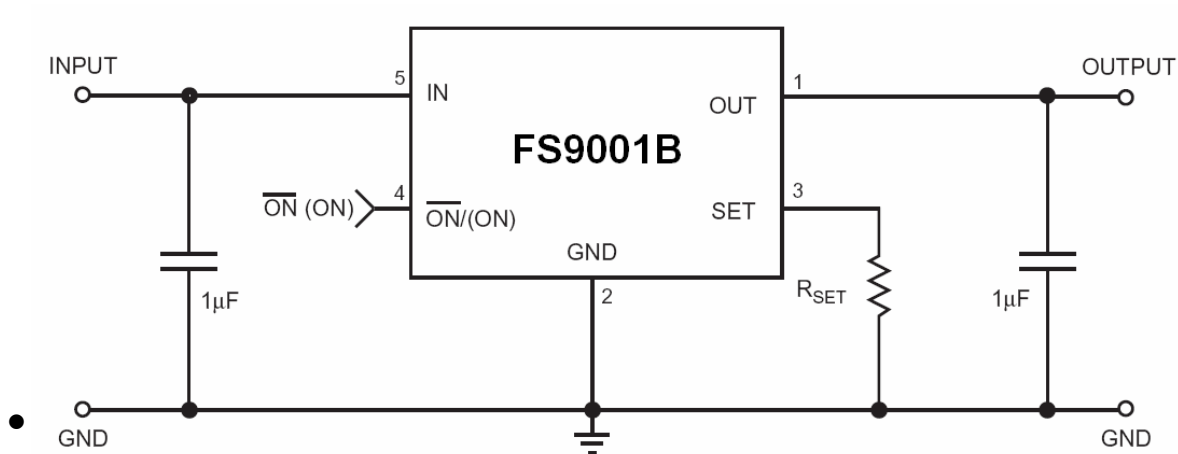

Operation

FS9001B is an integrated power switch with a low $R_{ds(on)}$ P-channel MOSFET, internal gate drive circuit, programmable current limiting, and thermal protection. When the FS9001B turns on, it can deliver up to 1A continuous current to load. When the device is active, if there is no load, the device only consumes 25µA supply current, which makes the device suitable for battery powered applications.

Power Supply Considerations

A 1µF ceramic bypass capacitor between IN and GND, close to the device, is recommended. Placing a high-value electrolytic capacitor on the output pin(s) is recommended when the output load is heavy. This precaution reduces power-supply transients that may cause ringing on the input and minimize the input voltage droops. Additionally, bypassing the output with a 1µF ceramic capacitor improves the immunity of the device to short-circuit transients.

Programmable Current Limiting

A sense FET is employed to check for overcurrent conditions. Unlike current-sense resistors, sense FETs do not increase the series resistance of the current path. When an overcurrent condition is detected, the device maintains a constant output current and reduces the output voltage accordingly. The current limit threshold is set by an external resistor on SET pin. Check the characteristic curve or the electrical characteristic table to find out an appropriate SET resistor value for a specific application.

Power Dissipation and Junction Temperature

The low on-resistance on the P-channel MOSFET allows the small surface-mount packages to pass large currents. It is good design practice to check power dissipation and junction temperature for each application. Begin by determining the $R_{DS(ON)}$ of the P-channel MOSFET relative to the input voltage and operating temperature. Using the highest operating ambient temperature of interest and $R_{DS(ON)}$, the power dissipation per switch can be calculated by:

$$PD = R_{DS(ON)} \times I^2$$

Finally, calculate the junction temperature:

$$T_J = P_D \times R_{\theta JA} + T_A$$

Where:

T_A = Ambient temperature

$R_{\theta JA}$ = Thermal resistance

P_D = Total power dissipation

FS9001B

Compare the calculated junction temperature with the maximum junction temperature which is 125°C. If they are within degrees, either the maximum load current needs to be reduced or another package option will be required.

Thermal Protection

Thermal protection prevents damage to the IC when heavy-overload or short-circuit faults are present for extended periods of time. The FS9001B implements a thermal sensing to monitor the operating junction temperature of the power distribution switch. In an overcurrent or short-circuit condition, the junction temperature rises due to excessive power dissipation. Once the die temperature rises to approximately 135°C due to overcurrent conditions, the internal thermal sense circuitry turns the power switch off, thus preventing the power switch from damage. Hysteresis is built into the thermal sense circuit, and after the device has cooled approximately 15°C, the switch turns back on. The switch continues to cycle in this manner until the load fault or input power is removed.