

## Fixed Frequency White LED Step-Up Converter

### ● Features

Drives Up to 10 Series White LEDs from 2.5V  
 Drives Up to 12 Series White LEDs from 3.6V  
 Up to 87% Efficiency  
 1.25MHz Fixed Switching Frequency  
 Low 300mV Feedback Voltage  
 Open Load Shutdown  
 Soft Start/PWM Dimming  
 SOT23-6L

### ● Applications

Cell Phones  
 Handheld Computers and PDAs  
 Digital Cameras  
 Small LCD Displays

### ● General Description

The FS1710 is a step-up DC/DC converter designed for driving up to 12 white LEDs in series from a single cell Lithium Ion battery with constant current. Because it directly regulates output current, the FS1710 is ideal for driving light emitting diodes (LEDs) whose light intensity is proportional to the current passing through them, not the voltage across their terminals. A single external resistor sets LED current between 5mA and 25mA, which can then be easily adjusted using either a DC voltage or a pulse width modulated (PWM) signal. Its low 300mV feedback voltage reduces power loss and improves efficiency. The OV pin monitors the output voltage and turns off the converter if an over-voltage condition is present due to an open circuit condition. The FS1710 is available in SOT23-6 packages.

### ● Pin Configurations

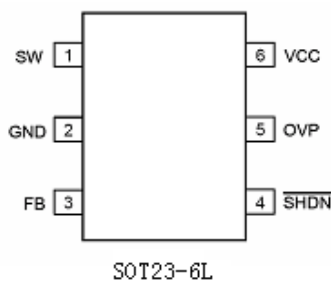

### ● Typical Application Circuit

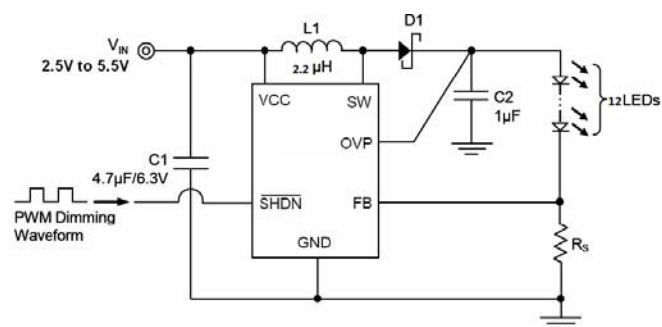

- Absolute Maximum Ratings**

Parameter	Ratings
VCC, SHDN to GND.	-0.3V to +6 V
FB to GND	-0.3V to V <sub>CC</sub>
SW, OVP to GND	-0.3V to +42V
Operating Temperature	-40°C to 85°C
Junction Temperature	125°C
Storage Temperature	-65°C to 150°C
Reflow Temperature (soldering, 10sec)	260°C
ESD Rating (Human Body Model)	2kV
Stress beyond those listed under "Absolute Maximum Rating" may cause permanent damage to the device.	

- Electrical Characteristics** @ ( V<sub>CC</sub>=V<sub>SHDN</sub> =3.6V, T<sub>A</sub>=25°C, unless otherwise specified )

Parameter	Conditions	Min	Typ	Max	Units
Input Voltage Range		2.5		5.5	V
Over Voltage Protection Threshold			28		V
OVP Pin Input Current	V <sub>ovp</sub> = 16V		60		μA
Quiescent Current	V <sub>FB</sub> = 0.3V (no switching)		80	120	μA
	V <sub>FB</sub> = 0.2V (switching)			2	mA
	V <sub>SHDN</sub> = 0V		0.1	1	μA
FB Comparator Trip Point	Initial Accuracy	280	300	320	mV
	Temperature Coefficient		100		ppm/°C
Switching Frequency		1	1.25	1.5	MHz
Maximum Duty		85			%
Switch R <sub>DS(ON)</sub>	I <sub>SW</sub> = 150mA		0.3		Ω
Switch Leakage Current	V <sub>SW</sub> = 20V		0.1	10	μA
Switch Current Limit			1.5		A
SHDN Pin Voltage High		1.5			V
SHDN Pin Voltage Low				0.4	V

## ● Typical Block Diagram

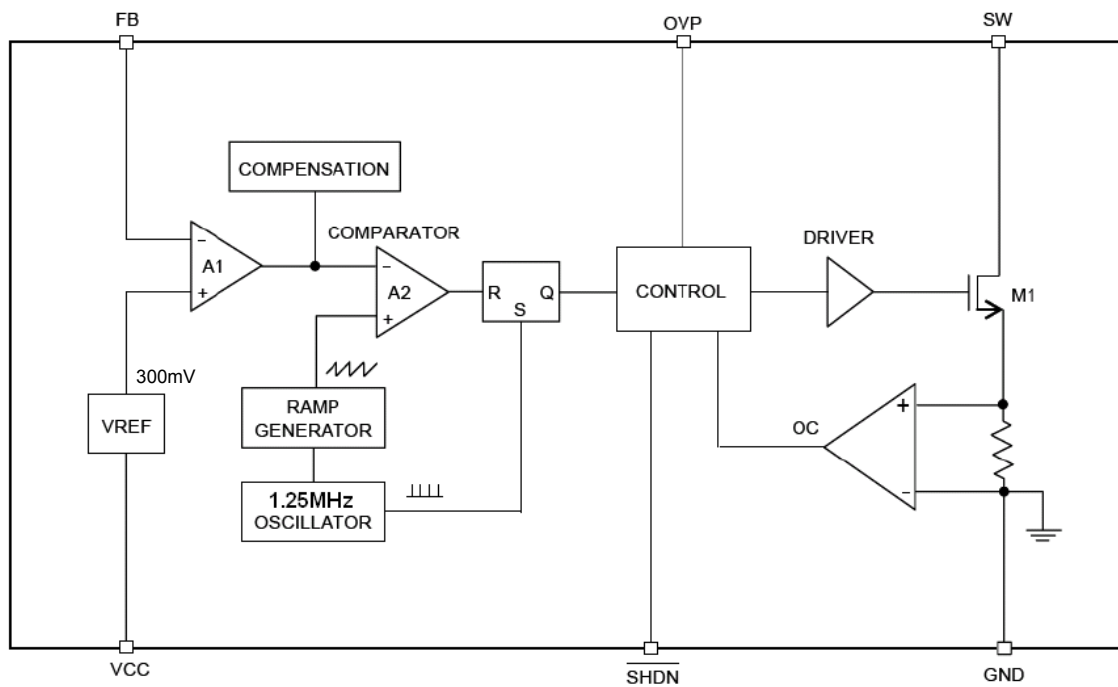

## ● Pin Description

Pin	Name	Function
1	SW	Switch Pin. The drain of the internal NMOS power switch. Connect this pin to inductor.
2	GND	Ground Pin.
3	FB	Feedback Pin. Connect current setting resistor $R_s$ from this pin to ground. The LED current is set as $0.300V/R_s$ .
4	SHDN	Active Low Shutdown Pin.
5	OVP	Over Voltage Protection Sense Pin.
6	VCC	Input Supply Pin. Bypass this pin with a capacitor as close to the device as possible.

## ● Function Description

The FS1710 uses a constant frequency control scheme to provide excellent line and load regulation. Operation can be best understood by referring to the block diagram. At the start of each oscillator cycle, the SR latch is set, which turns on the power switch M1. An artificial ramp is generated to the positive terminal of the PWM comparator A2. When this voltage exceeds the level at the negative input of A2, the SR latch is reset turning off the power switch. The level at the negative input of A2 is set by the error amplifier A1, and is simply an amplified version of the difference between the feedback voltage and the reference voltage of 0.300V. In this manner, the error amplifier sets the correct peak current level to keep the output in regulation. If the error amplifier's output increases, more current is delivered to the output, if it decreases, less current is delivered.

Over voltage protection function is designed to prevent the damage of internal NMOS switch in case the increased impedance of the LED load (include the LED opened). Once the device detects over voltage (typical 40V) at the output, the internal NMOS switch is kept off until the output voltage drops.

- **Application Information**

### ***Inductor Selection***

A 2.2 $\mu$ H inductor is recommended for FS1710 applications. Small size and high efficiency are the major concerns for most FS1710 applications. Inductor with low core losses and small DCR (cooper wire resistance) at 1.25MHz are good choice for FS1710 applications.

Since the FS1710 is designed to operate in discontinuous mode, the inductor current reaches zero during discharge phase. After the inductor current reaches zero, the switch pin exhibits ringing due to the LC tank circuit formed by the inductor in combination with switch and diode capacitance. This ringing is not harmful; far less spectral energy is contained in the ringing than in the switch transitions. The ringing can be damped by application of a 300 $\Omega$  resistor across the inductor, although this will degrade efficiency.

### ***Capacitor Selection***

The small size of ceramic capacitors makes them suitable for FS1710 applications. X5R and X7R types are recommended because they retain their capacitance over wider voltage and temperature ranges than other types such as Y5V or Z5U. A minimum 1 $\mu$ F capacitor for output is required for most applications. Larger input/output capacitor minimizes input/output ripple.

### ***Diode Selection***

Schottky diodes, with their low forward voltage drop and fast reverse recovery, are the ideal choices for FS1710 applications. The forward voltage drop of a Schottky diode represents the conduction losses in the diode, while the diode capacitance (CT or CD) represents the switching losses. For diode selection, both forward voltage drop and diode capacitance need to be considered. Schottky diodes with higher current ratings usually have lower forward voltage drop and larger diode capacitance, which can cause significant switching losses at the 1.25MHz switching frequency of the FS1710. A Schottky diode rated at 1.5A is sufficient for most FS1710 applications.

- Typical Performance Characteristics

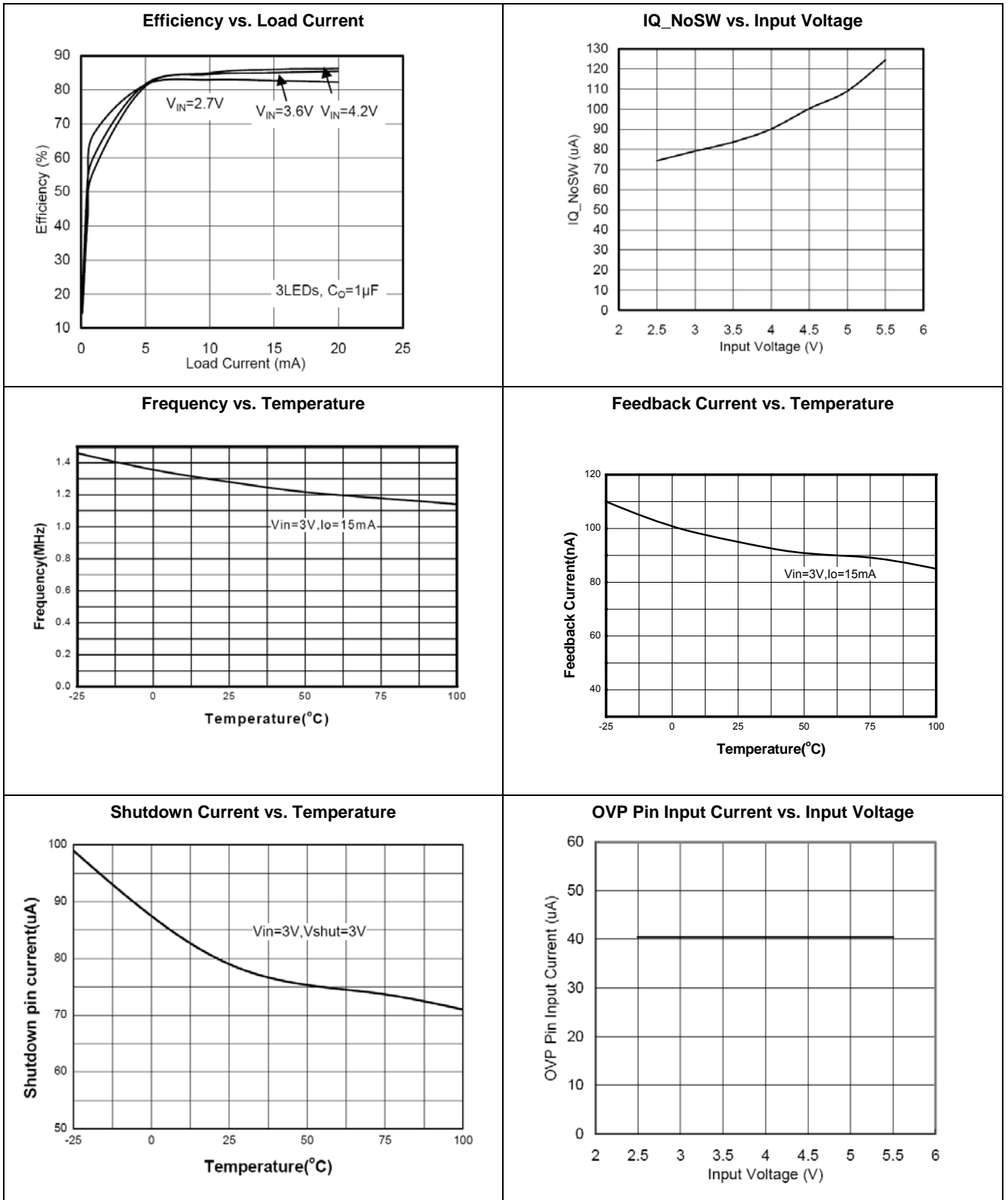

● Package Information

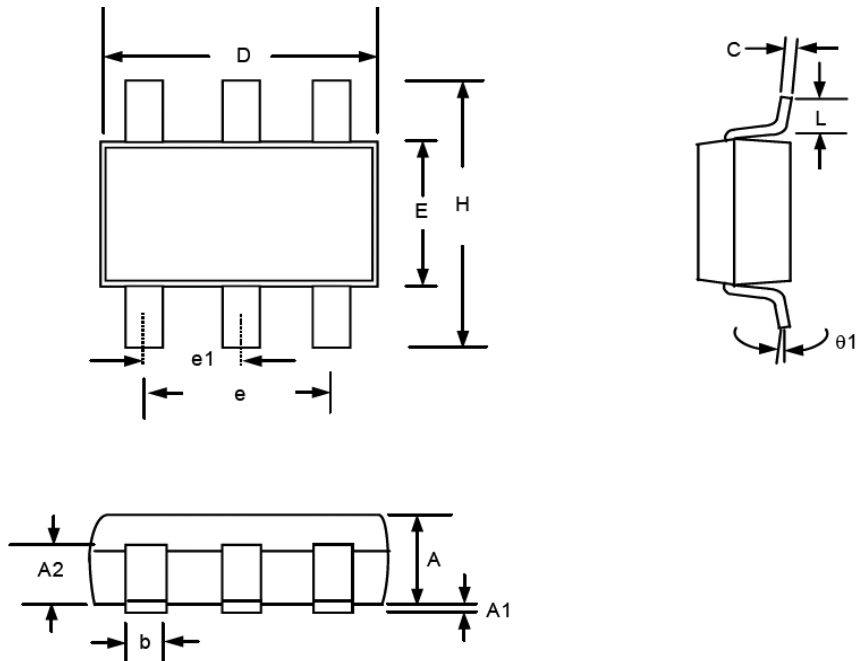

Symbol	Dimension mm			Dimension in inch		
	Min	Nom	Max	Min	Nom	Max
A	1.00	1.10	1.30	0.039	0.043	0.051
A1	0.00		0.10	0.000		0.004
A2	0.70	0.80	0.90	0.028	0.031	0.035
b	0.35	0.40	0.50	0.014	0.016	0.020
C	0.10	0.15	0.25	0.004	0.006	0.010
D	2.70	2.90	3.10	0.106	0.114	0.122
E	1.40	1.60	1.80	0.055	0.063	0.071
e	1.90(TYP)			0.075(TYP)		
H	2.60	2.80	3.00	0.102	0.110	0.118
L	0.37			0.015		
$\theta 1$	1°	5°	9°	1°	5°	9°