

## Fixed Frequency White LED Step-Up Converter

- **Features**

- Inherently Matched LED Current
- High Efficiency: 87%
- Drives Up to Five LEDs from 2.5V Supply
- 24V Internal Power Switch
- Fast 1MHz Switching Frequency
- Uses Tiny 1mm Tall Inductors
- Requires Only 1 $\mu$ F Output Capacitors
- 19.5V Over Voltage Protection
- SOT-23-6L Package

- **Applications**

- White LED Backlight Display for PDA
- Pocket PC
- Smart Phones
- Handheld Devices
- Cellular Phones

- **General Description**

The FS1706 is a step-up DC/DC converter specifically designed to drive up to 5 series white LEDs with constant current. Series connection of the LEDs provides identical LED currents resulting in uniform brightness and eliminates the need for ballast resistors. The FS1706 switches at 1MHz, allowing the use of tiny external components. A low 0.254V feedback voltage minimizes power loss in the current setting resistor for high efficiency. The OVP pin monitors the output voltage and turns off the converter whenever the LEDs are open.

The FS1706 is available in low profile SOT-23-6L package.

- **Pin Configurations**

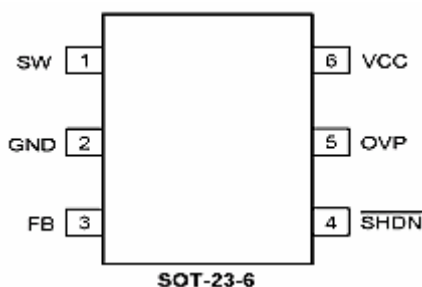

- **Typical Application Circuit**

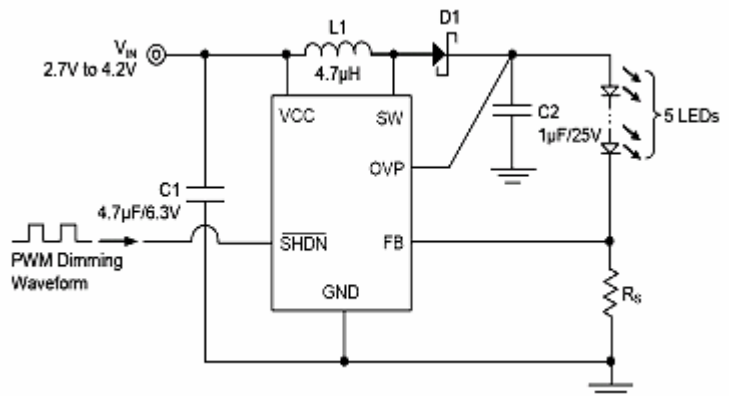

● **Typical Block Diagram**

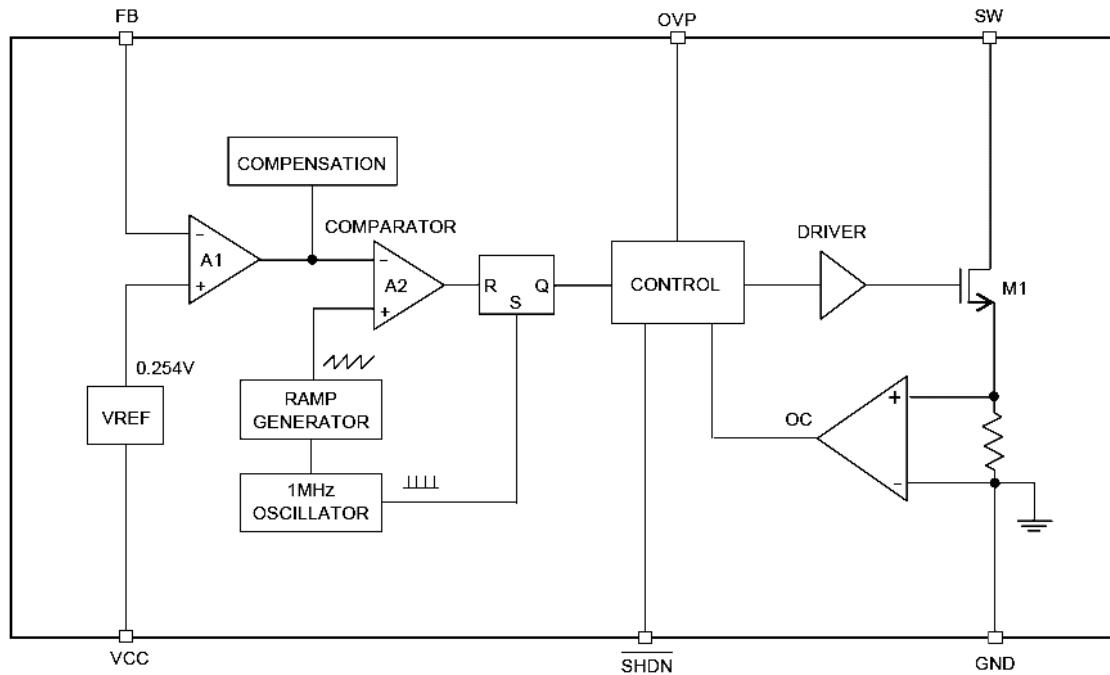

● **Pin Description**

Pin	Name	Function
1	SW	Switch Pin. The drain of the internal NMOS power switch. Connect this pin to inductor.
2	GND	Ground Pin.
3	FB	Feedback Pin. Connect current setting resistor $R_s$ from this pin to ground. The LED current is set as $0.254V / R_s$ .
4	SHDN	Active Low Shutdown Pin.
5	OVP	Over Voltage Protection Sense Pin.
6	VCC	Input Supply Pin. Bypass this pin with a capacitor as close to the device as possible.

● **Absolute Maximum Ratings**

Parameter	Ratings
VCC, SHDN to GND.	-0.3V to +7 V
FB to GND	-0.3V to VCC V
SW, OVP to GND	-0.3V to +24V
Operating Temperature	-40°C to 85°C
Junction Temperature	125°C
Storage Temperature	-65°C to 150°C
Reflow Temperature (soldering, 10sec)	260°C
ESD Rating (Human Body Model)	2kV
Stress beyond those listed under "Absolute Maximum Rating" may cause permanent damage to the device.	

## ● Electrical Characteristics

(  $V_{CC}=V_{SHDN}=3.6V$ ,  $T_A=25^{\circ}C$ , unless otherwise specified )

Parameter	Conditions	Min	Typ	Max	Units
Input Voltage Range		2.5	-	6	V
Input Voltage UVLO		1.7	2.0	2.3	V
Over Voltage Protection Threshold	trigger	18.5	19.5	21	V
Over Voltage Protection Threshold	release	13.5	15	16.5	V
OVP Pin Input Current	$V_{ovp} = 16V$	-	40	60	$\mu A$
	$V_{FB} = 0.3V$ (no switching)	-	80	120	$\mu A$
Quiescent Current	$V_{FB} = 0.2V$ (switching)	-	-	2	mA
	$V_{SHDN} = 0V$	-	0.1	1	$\mu A$
FB Comparator Trip Point	Initial Accuracy	244	254	264	mV
	Temperature Coefficient	-	100	-	ppm/ $^{\circ}C$
Switching Frequency	$V_{FB} = 0.2V$	0.8	1.0	1.2	MHz
Maximum Duty		85	-	-	%
Switch $R_{DS(ON)}$	$I_{SW} = 150mA$	-	0.7	1.0	$\Omega$
Switch Leakage Current	$V_{SW} = 20V$	-	0.1	10	$\mu A$
Switch Current Limit		500	600	700	mA
Soft Start Time		-	120	-	$\mu s$
SHDN Pin Voltage High		2	-	-	V
SHDN Pin Voltage Low		-	-	0.8	V

## ● Function Description

The FS1706 uses a constant frequency control scheme to provide excellent line and load regulation. Operation can be best understood by referring to the block diagram. At the start of each oscillator cycle, the SR latch is set, which turns on the power switch M1. An artificial ramp is generated to the positive terminal of the PWM comparator A2. When this voltage exceeds the level at the negative input of A2, the SR latch is reset turning off the power switch. The level at the negative input of A2 is set by the error amplifier A1, and is simply an amplified version of the difference between the feedback voltage and the reference voltage of 0.254V. In this manner, the error amplifier sets the correct peak current level to keep the output in regulation. If the error amplifier's output increases, more current is delivered to the output, if it decreases, less current is delivered.

Over voltage protection function is designed to prevent the damage of internal NMOS switch in case the increased impedance of the LED load (include the LED opened). Once the device detects over voltage (typical 19.5V) at the output, the internal NMOS switch is kept off until the output voltage drops below 15V.

---

- **Application Information**

### ***Inductor Selection***

A 4.7 $\mu$ F inductor is recommended for FS1706 applications. Small size and high efficiency are the major concerns for most FS1706 applications. Inductor with low core losses and small DCR (copper wire resistance) at 1MHz are good choice for FS1706 applications.

Since the FS1706 is designed to operate in discontinuous mode, the inductor current reaches zero during discharge phase. After the inductor current reaches zero, the switch pin exhibits ringing due to the LC tank circuit formed by the inductor in combination with switch and diode capacitance. This ringing is not harmful; far less spectral energy is contained in the ringing than in the switch transitions. The ringing can be damped by application of a 300 $\Omega$  resistor across the inductor, although this will degrade efficiency.

### ***Capacitor Selection***

The small size of ceramic capacitors makes them suitable for FS1706 applications. X5R and X7R types are recommended because they retain their capacitance over wider voltage and temperature ranges than other types such as Y5V or Z5U. A minimum 1 $\mu$ F capacitor for output is required for most applications. Larger input/output capacitor minimizes input/output ripple.

### ***Diode Selection***

Schottky diodes, with their low forward voltage drop and fast reverse recovery, are the ideal choices for FS1706 applications. The forward voltage drop of a Schottky diode represents the conduction losses in the diode, while the diode capacitance (CT or CD) represents the switching losses. For diode selection, both forward voltage drop and diode capacitance need to be considered. Schottky diodes with higher current ratings usually have lower forward voltage drop and larger diode capacitance, which can cause significant switching losses at the 1MHz switching frequency of the FS1706. A Schottky diode rated at 500mA is sufficient for most FS1706 applications.

- Typical Performance Characteristics

Efficiency vs. Load Current

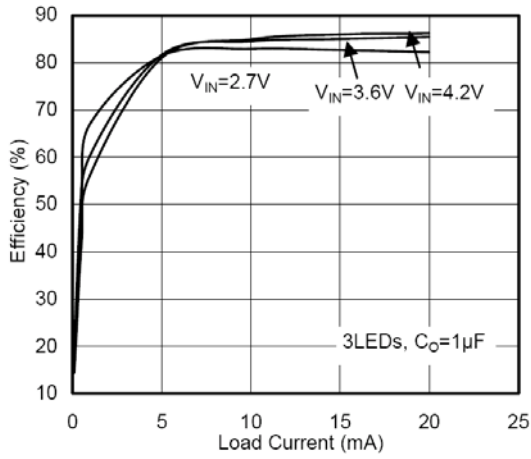

IQ\_NoSW vs. Input Voltage

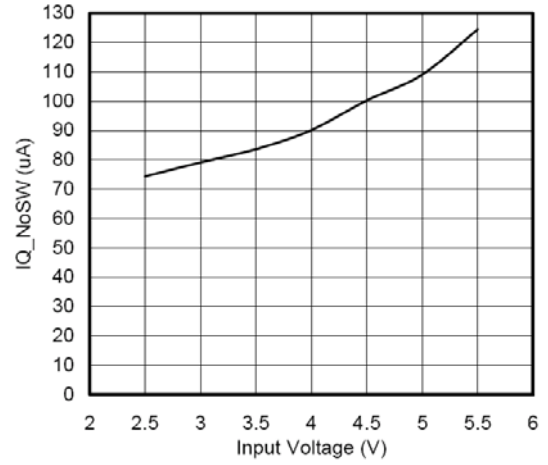

Frequency vs. Input Voltage

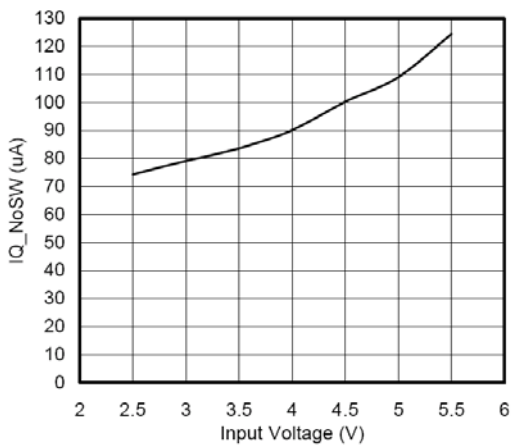

OVP Trigger Threshold vs. Input Voltage

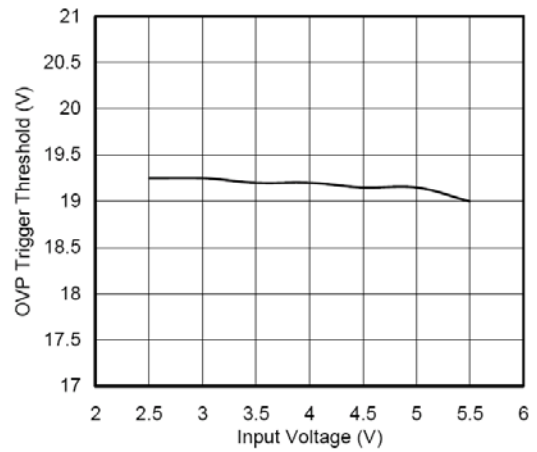

OVP Release Threshold vs. Input Voltage

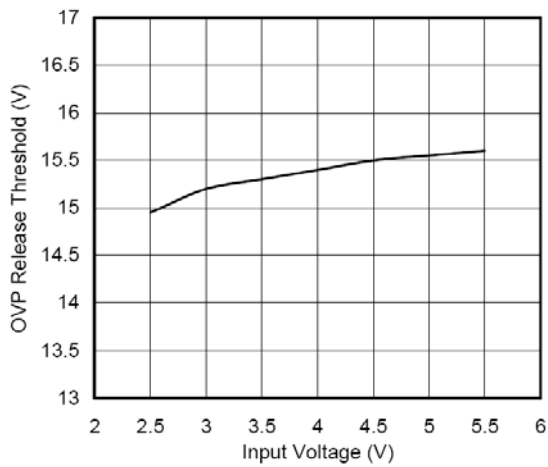

OVP Pin Input Current vs. Input Voltage

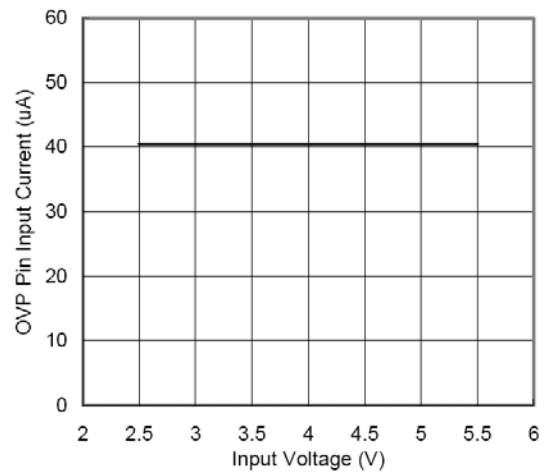

● Package Information

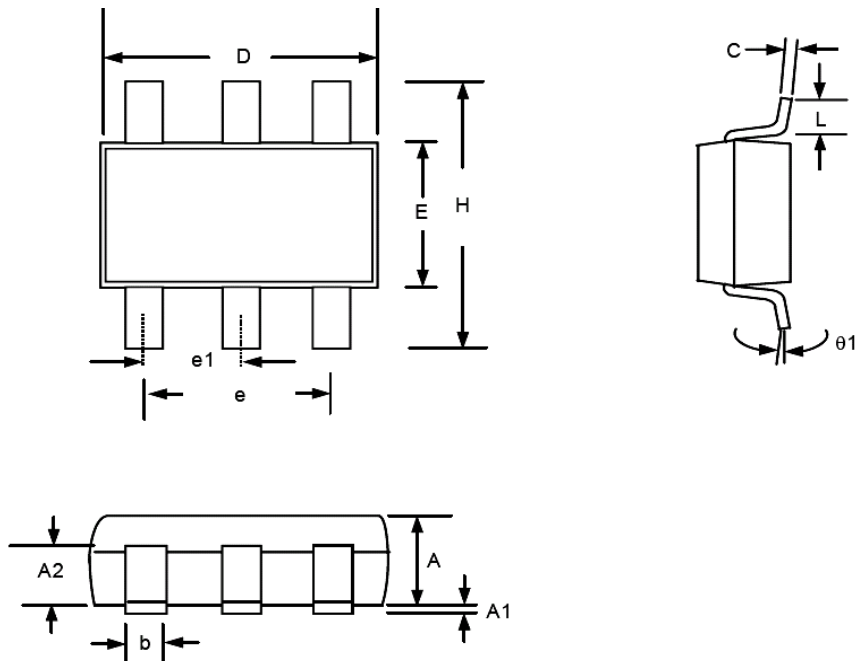

Symbol	Dimension mm			Dimension in inch		
	Min	Nom	Max	Min	Nom	Max
A	1.00	1.10	1.30	0.039	0.043	0.051
A1	0.00	-	0.10	0.000	-	0.004
A2	0.70	0.80	0.90	0.028	0.031	0.035
b	0.35	0.40	0.50	0.014	0.016	0.020
C	0.10	0.15	0.25	0.004	0.006	0.010
D	2.70	2.90	3.10	0.106	0.114	0.122
E	1.40	1.60	1.80	0.055	0.063	0.071
e	-	1.90(TYP)	-	-	0.075(TYP)	-
H	2.60	2.80	3.00	0.102	0.110	0.118
L	0.37	-	-	0.015	-	-
θ 1	1°	5°	9°	1°	5°	9°