

P-Channel 30V (D-S) MOSFET

- Features**

-30V/-4.5A, $R_{DS(ON)}=60m\Omega@V_{GS}=-10V$

-30V/-3.7A, $R_{DS(ON)}=90m\Omega@V_{GS}=-4.5V$

Super high density cell design for

extremely low $R_{DS(ON)}$

Exceptional on-resistance and maximum DC current capability

- General Description**

The FS5905 is the Dual P-Channel logic enhancement mode power field effect transistors are produced using high cell density, DMOS trench technology. This high density process is especially tailored to minimize on-state resistance. These devices are particularly suited for low voltage application such as cellular phone and notebook computer power management and other battery powered circuits where high-side switching, and low in-line power loss are needed in a very small outline surface mount package.

- Applications**

Power Management in Note book

Portable Equipment

Battery Powered System

DC/DC Converter

Load Switch

DSC

LCD Display inverter

- Pin Configurations**

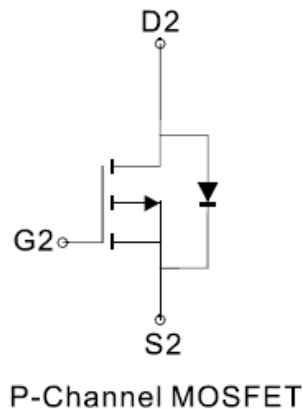
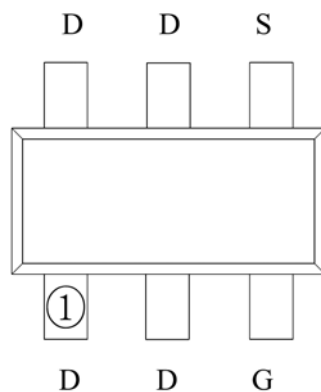

● **Absolute Maximum Ratings @ $T_A=25^\circ\text{C}$ unless otherwise noted**

Parameter	Symbol	Limits	Units
Drain-Source Voltage	V_{DS}	-30	V
Gate-Source Voltage	V_{GS}	± 20	V
Continuous Drain Current ($t_j=150$)	I_D	$T_a=25$	-4.5
		$T_a=70$	-3.6
Pulsed Drain Current ¹⁾	I_{DM}	-30	A
Continuous Drain Current (Diode Conduction)	I_s	-1.7	A
Maximum Power Dissipation	P_D	$T_A=25$	1.25
		$T_A=70$	0.8
Operating Junction Temperature	T_J	-55 to 150	$^\circ\text{C}$
Storage Temperature Range	T_{stg}	-55 to 150	
Thermal Resistance- Junction-to-Ambient *	R_{JA}		42
		Steady State	55
Thermal Resistance- Junction-to-Case	R_{Jc}	35	W

Notes: *The device mounted on 1in2 FR4 board with 2 oz copper

● **Electrical Characteristics @ $T_A=25^\circ\text{C}$ unless otherwise Specified**

Symbol	Parameter	Conditions	Min	Typ	Max	Units
Static						
$V_{GS(th)}$	Gate Threshold Voltage	$V_{GS} = V_{DS}, I_D = -250\text{ A}$	-1	-1.4	-2	V
I_{GSS}	Gate Leakage Current	$V_{DS} = 0\text{V}, V_{GS} = \pm 20\text{V}$	-	-	± 100	nA
I_{DSS}	Zero Gate Voltage Drain Current	$V_{DS} = -30\text{V}, V_{GS} = 0\text{V}$	-	-	-1	μA
		$V_{DS} = -30\text{V}, V_{GS} = 0\text{V}, T_J=55$	-	-	-25	
$I_{D(ON)}$	On-State Drain Current	$V_{DS} = -5\text{V}, V_{GS} = -10\text{V}$	-20	-	-	A
$R_{D(ON)}$	Drain-Source On-Resistance	$V_{GS} = -10\text{V}, I_D = -5.3\text{ A}$	-	50	60	m Ω
		$V_{GS} = -4.5\text{V}, I_D = -4.2\text{ A}$	-	69	90	
V_{SD}	Diode Forward Voltage	$I_s = -1.7\text{A}, V_{GS} = 0\text{V}$	-	-0.8	-1.2	V
Dynamic						
R_g	Gate resistance	$V_{DS}=0\text{V}, V_{GS}=0\text{V}, f=1\text{MHz}$	-	3.5	-	Ω
C_{iss}	Input capacitance	$V_{DS}=-15\text{V}, V_{GS}=-0\text{V}, f=1\text{MHz}$	-	450	490	pF
C_{oss}	Output Capacitance		-	70	-	
C_{rss}	Reverse Transfer Capacitance		-	20	-	
Q_g	Total Gate Charge	$V_{DS}=-15\text{V}, V_{GS}=-10\text{V}, I_D=-5.3\text{A}$	-	14	17	nC
Q_{gs}	Gate-Source Charge		-	4	-	
Q_{gd}	Gate-Drain Charge		-	3	-	
$t_{D(on)}$	Turn-On Delay Time	$V_{DD} = -15\text{V}, R_L = 15\Omega$ $I_D = -1\text{A}, V_{GEN} = -10\text{V}$ $R_G = 6\Omega$	-	27	33	ns
t_r	Turn-On Rise Time		-	11	15	
$t_{D(off)}$	Turn-Off Delay Time		-	40	52	
t_f	Turn-Off Fall Time		-	4	6	

● Typical Performance Characteristics ($T_J=25$)

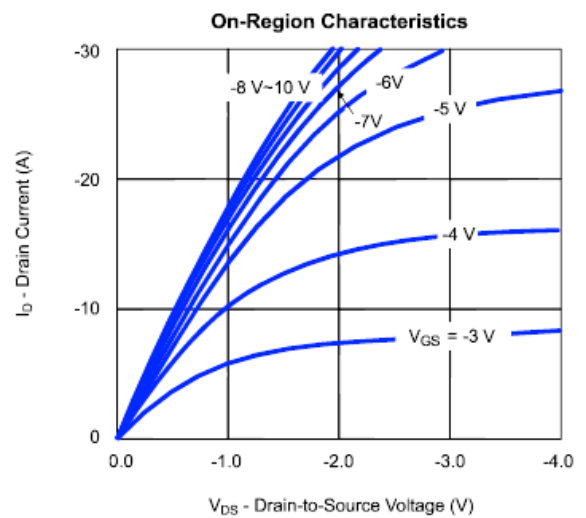
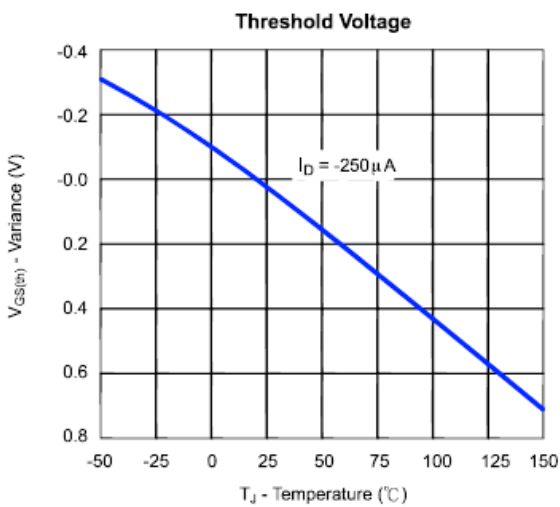
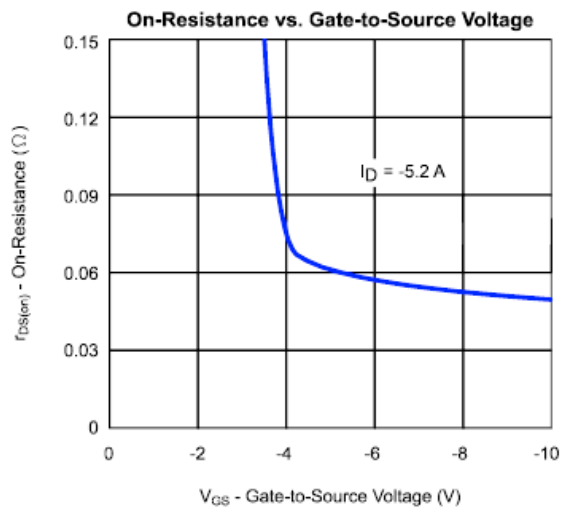
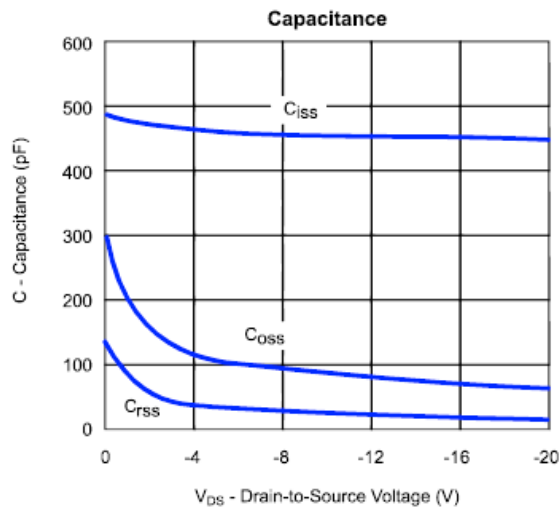
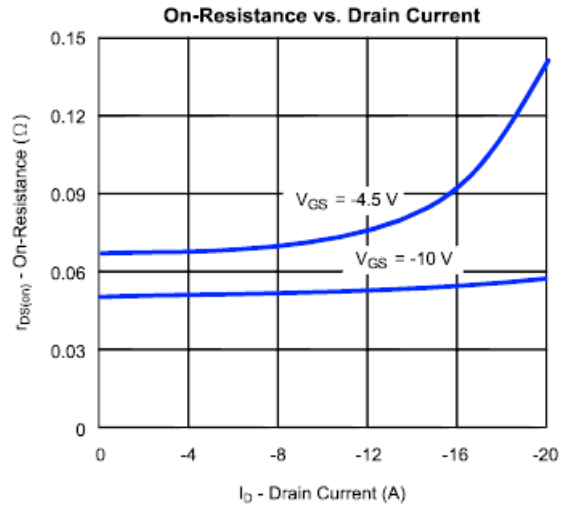
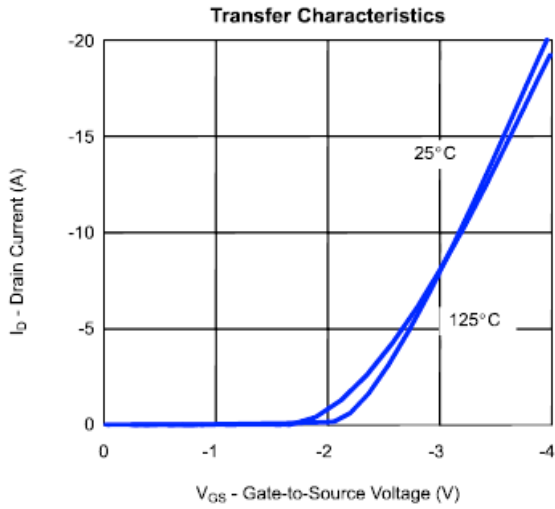

FS5905

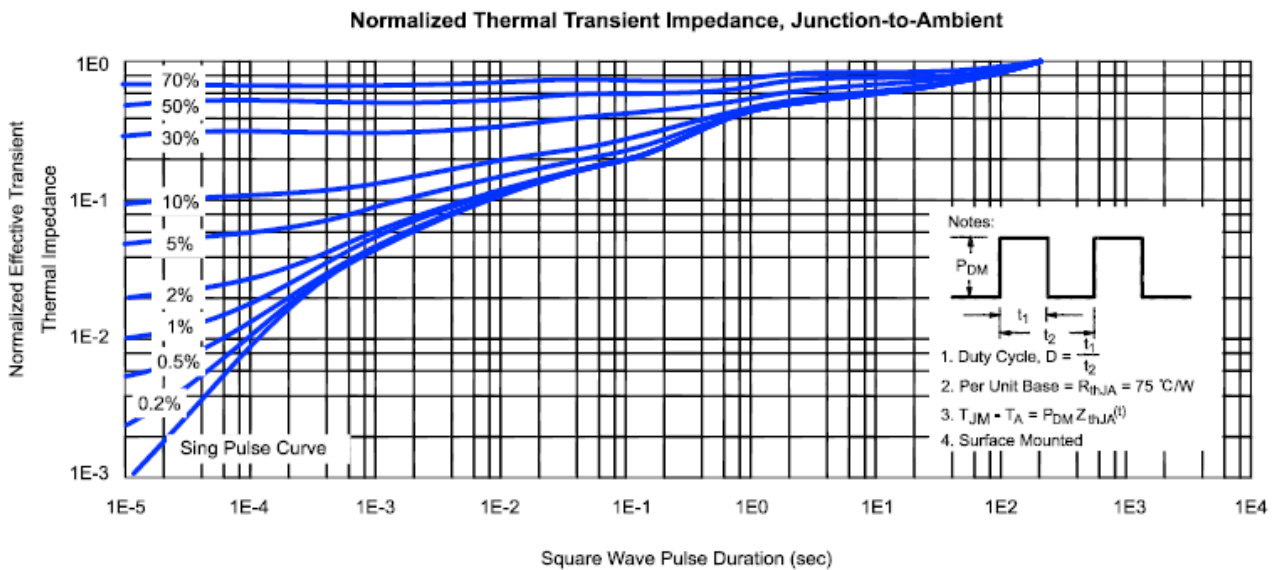
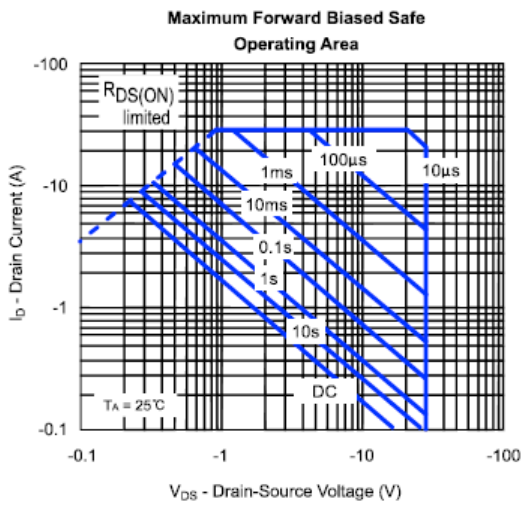
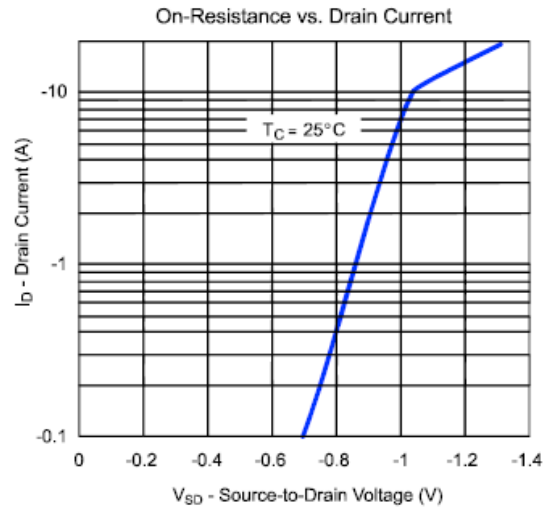
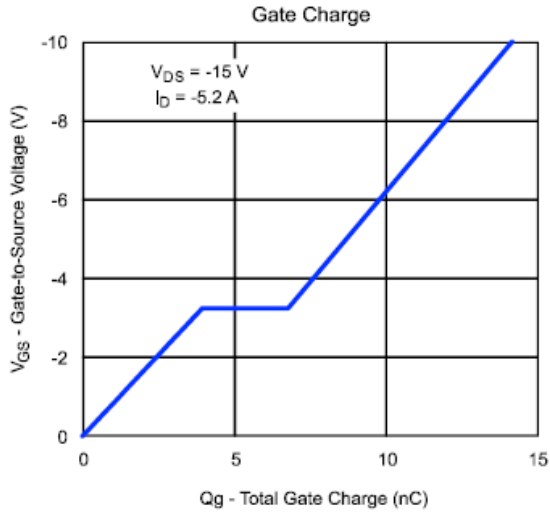

- Package Information

SOT-23-6L PACKAGE OUTLINE DIMENSIONS

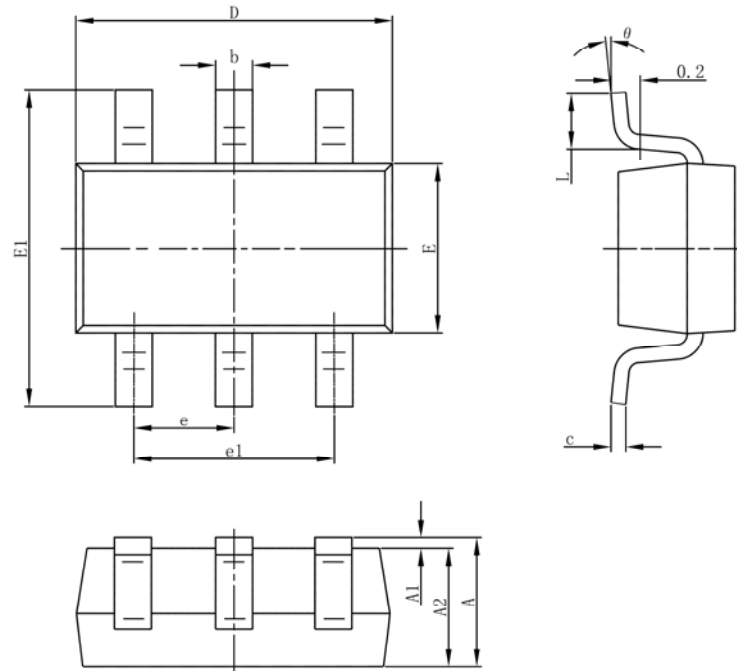

Symbol	Dimensions In Millimeters		Dimensions In Inches	
	Min	Max	Min	Max
A	1.050	1.250	0.041	0.049
A1	0.000	0.100	0.000	0.004
A2	1.050	1.150	0.041	0.045
b	0.300	0.500	0.012	0.020
c	0.100	0.200	0.004	0.008
D	2.820	3.020	0.111	0.119
E	1.500	1.700	0.059	0.067
E1	2.650	2.950	0.104	0.116
e	0.950(BSC)		0.037(BSC)	
e1	1.800	2.000	0.071	0.079
L	0.300	0.600	0.012	0.024
θ	0°	8°	0°	8°