

2MHz 2A MAX Output Synchronous Step Down Converter

- **Features**

- Soft Start
- Internal Current Limit
- High Efficiency – Up to 95%
- Very Low Quiescent Current of 40uA
- MAX 2A Output Current at $V_{IN}=3V$
- 2MHz Constant Frequency Operation
- Internal Synchronous Rectifier Eliminates Schottky Diode
- Adjustable Output Voltages From 0.6V to V_{IN}
- Fixed Output Voltage Options Available
- 100% Duty Cycle Low-Dropout Operation
- 0.1uA Shutdown Current
- Tiny SOT23-5L Package

- **Applications**

- Blue Tooth Headsets
- Portable Audio Players
- Mobile Phones
- Wireless and DSL Modems
- Digital Cameras
- Portable Instruments

- **General Description**

The FS1405 is a fixed-frequency current-modes Synchronous PWM step down converter that is capable of delivering MAX 2A of output current while achieving peak efficiency of 95%. Under light load conditions, the FS1405 operates in a proprietary pulse skipping mode that consumes just 40uA of supply current, maximizing battery life in portable applications. The FS1405 operates with a fixed frequency of 2MHz, minimizing noise in noise-sensitive applications and allowing the use of small external components. The FS1405 is an ideal solution for applications powered by Li-Ion batteries or other portable applications that require small board space.

The FS1405 is available in an adjustable output voltage version capable of generating output voltage version from 0.6V to V_{IN} . The FS1405 is available in the tiny 6-pin SOT23-5L package.

- **Pin Configurations**

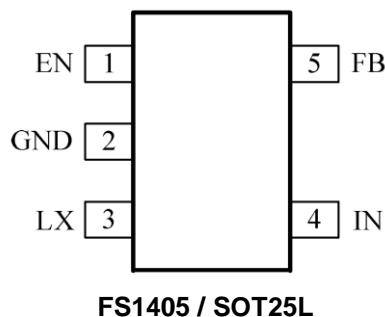

FS1405

● Absolute Maximum Ratings

Parameter	Symbol	Ratings	Unit
IN Pin Voltage	V_{IN}	-0.3 to 7V	V
FB Pin Voltage	V_{FB}	-0.3 to 7V	V
EN Pin Voltage	V_{EN}	-0.3 to 7V	V
SW Pin Voltage	V_{sw}	-0.3 to $V_{IN} + 0.3$	V
Continuous SW Current	I_{sw}	Internally limited	A
Maximum Power Dissipation (derate 5.3mW/°C above $T_A=50^\circ\text{C}$)	P_D	530	mW
Operating Junction Temperature	T_{opr}	-40 to + 150	°C
Storage Temperature Range	T_{stg}	-55 to + 150	
Lead Temperature (Soldering, 10 seconds)	T_{solder}	300	

● Electrical Characteristics

($V_{IN}=V_{EN}=3.6\text{V}$, $T_A=25^\circ\text{C}$ $C_{in}=4.7\mu\text{f}$ $C_{out}=10\mu\text{f}$ all capacitors are ceramic, unless otherwise specified.)

Parameter	Symbol	Conditions	Min	Typ	Max	Units
Input Voltage Range	V_{IN}		2.5		6.5	V
Under Voltage Lockout Threshold	V_{UVLO}	V_{IN} rising, hysteresis =0.1V	2.25	2.4	2.5	V
Operating Supply Current		$V_{FB}=60\%$, $I_{OUT}=0$	--	586	--	μA
Standby Supply Current		$V_{FB}=105\%$, $I_{OUT}=0$	--	33	40	μA
Shutdown Supply Current		$V_{EN}=0\text{V}$, $V_{IN}=4.2\text{V}$	--	0.1	5	μA
Adjustable Version Regulation Voltage	V_{FB}	$T_A=25^\circ\text{C}$	0.591	0.6	0.609	V
		$0^\circ\text{C}<T_A<85^\circ\text{C}$	0.588	0.6	0.612	V
		$-40^\circ\text{C}<T_A<85^\circ\text{C}$	0.582	0.6	0.618	V
Output Voltage Line Regulation		$V_{IN}=3\text{V}$ to 5V	--	0.016	0.4	%/V
Output Voltage Load Regulation		$I_{out}=10\text{mA}$ to 1500mA	--	1	--	%
Inductor Current Limit	I_{LIM}	$V_{IN}=3.0\text{V}$, $V_{FB}=90\%$ of $V_{out(NOM)}$	--	2.5	--	A
Oscillator Frequency	f_{SW}	V_{FB} or V_{OUT} in regulation		2		MHz
PMOS On Resistance	R_{ONP}	$I_{SW}=-100\text{mA}$	--	0.25	--	Ω
NMOS On Resistance	R_{ONN}	$I_{SW}=100\text{mA}$	--	0.23	--	Ω
SW Leakage Current		$EN=GND$, $V_{IN}=5.5\text{V}$ $V_{SW}=5.5\text{V}$	--	--	1	μA
EN Logic High Threshold	V_{IH}	$V_{IN}=2.7\text{V}$ to 5.5V	1.4	--	--	V
EN Logic Low Threshold	V_{IL}	$V_{IN}=2.7\text{V}$ to 5.5V			0.4	V
EN Input Bias Current	I_{EN}	$V_{IN}=5.5\text{V}$, $EN=GND$ or IN		0.01	0.1	μA

FS1405

- Typical Block Diagram

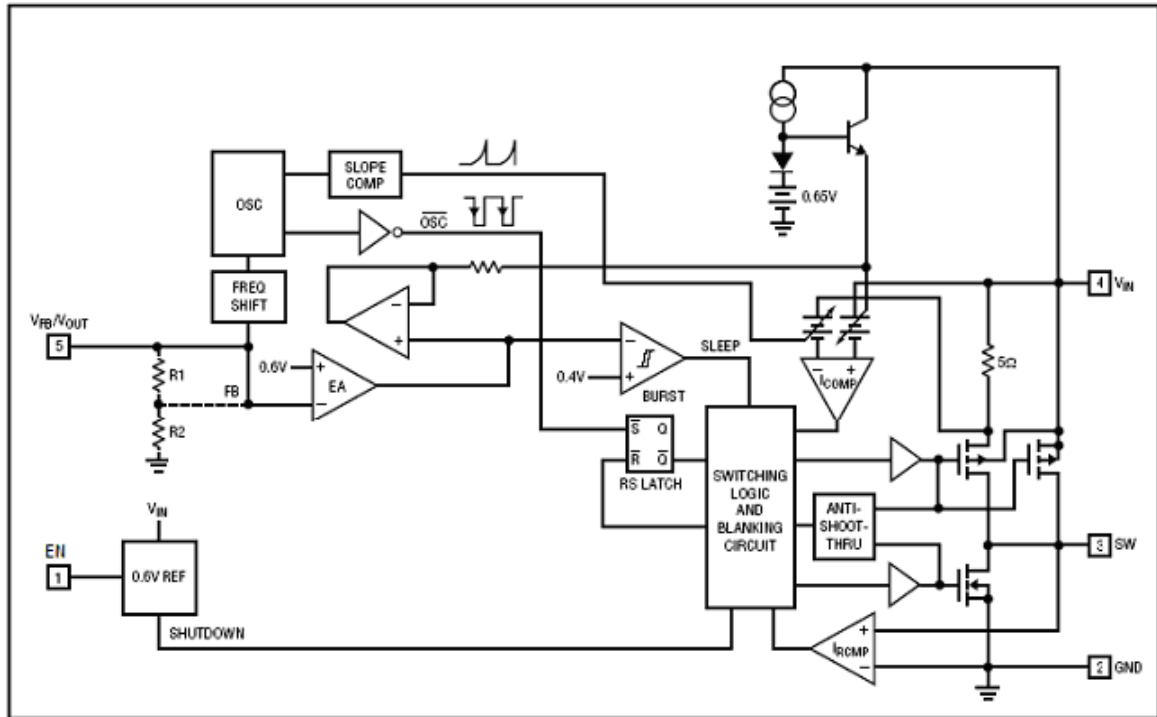

- Pin Description

FS1405 -①②③④

DESIGNATOR	SYMBOL	DESCRIPTION
①②	Output Detection Voltage	AD=ADJ
③④	Package Type:	SK: SOT23-5L

NO:	Pin Name	Pin Description
①	EN	Enable Control Input. Drive EN to IN or to a logic high for normal operation, drive to GND or a logic low to disable the regulator.
②	GND	Ground.
③	LX	Switching Node Output. Connect this pin to the switching end of the inductor.
④	IN	Power Input. Bypass to GND as close as possible to the IC with a high quality ceramic capacitor.
⑤	FB	Feedback Node. For fixed output voltage options, connects this pin directly to the output. For the Adjustable output version the voltage at this pin is regulated to 0.6V; connect to this pin to the center of the output voltage feedback network.

- Application Information

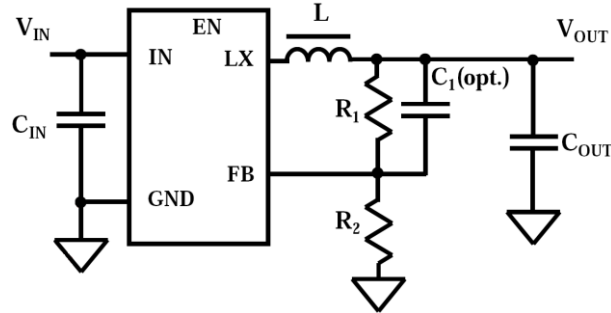

Application note:

- Inductor Value (Table 1)

Table 1. Typical Inductor Values

V _{OUT}	0.6V to 0.9V	0.9V to 1.8V	>1.8V
L	1.5uH	2.2uH	2.7uH

- C_{in}=4.7uF(ceramic capacitor).
- C_{out}=10uF(ceramic capacitor).
- Output Voltage Programming

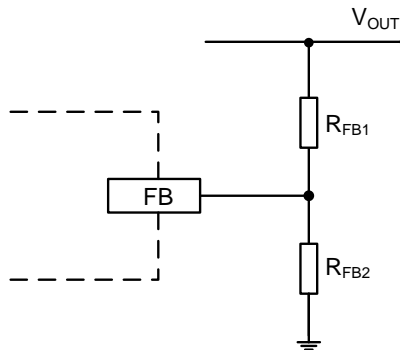

Figure 1. Output Voltage Programming

Figure 1 shows the Feedback network necessary to set the output voltage when the adjustable version is used. Select the proper ratio of the two feedback resistors R_{FB1} and R_{FB2} based on the desired output voltage. Typically choose R_{FB2} ≈ 100K Ω and determine R_{FB1} from the output voltage:

$$R_{FB1} = R_{FB2} \left(\frac{V_{OUT}}{0.6V} - 1 \right)$$

Connect a small capacitor across R_{FB1} for feed forward capacitance at the FB pin:

$$C_{ff} = 2 \times 10^{-5} / R_{FB1}$$

where R_{FB1}=900K Ω use 22pF. When using very low ESR output capacitors, such as ceramic, check for stability while examining load-transient response, and increase the compensation capacitor C₁ if needed.

5. Dropout Operation

As the input supply voltage decreases to a value approaching the output voltage, the duty cycle increases toward the maximum on-time. Further reduction of the supply voltage forces the main switch to remain on for more than one cycle until it reaches 100% duty cycle. Possible occurred larger ripple on the low-dropout operation. Recommended operating voltage $V_{IN} \geq V_{OUT} + 0.7V$

PCB layout caution

- 1、 The power traces, consisting of the GND trace, the SW trace and the V_{in} trace should be keep short, direct and wide.
- 2、 V_{fb} should be connected directly to the feedback resistors, The resistive divider R1/R2 must connected between the (+) plate of C_{out} and ground.
- 3、 The (+) plate of C_{in} should be connected to V_{in} as closely as possible, because this capacitor provides the AC current to the internal power MOSFETS.
- 4、 Keep the switching node SW away form the sensitive V_{fb} node
- 5、 Keep the (-) plates of C_{in} and C_{out} as close as possible
- 6、 The high current paths
- 7、 The recommended PCB layout

● Typical Performance Characteristics

For FS1405

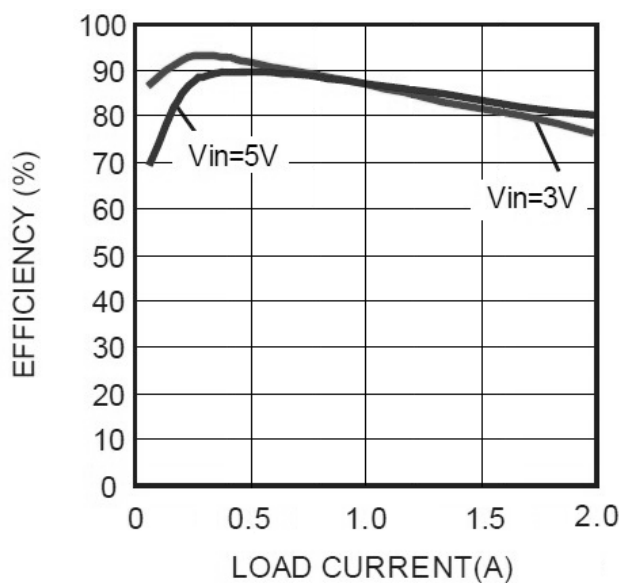

FS1405

Input Voltage VS Standby Supply Current

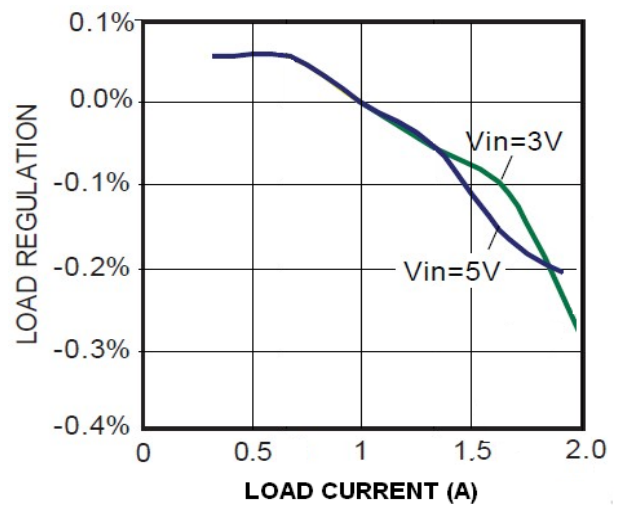
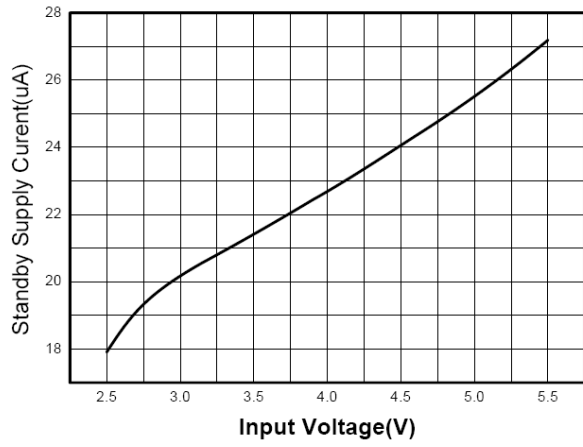

FS1405

- Package Information

SOT-23-5L PACKAGE OUTLINE DIMENSIONS

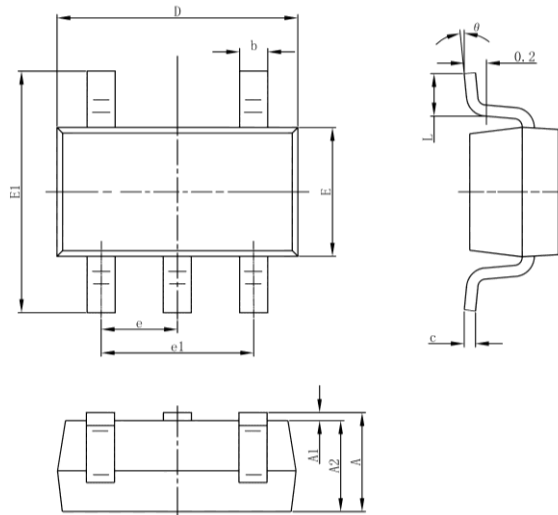

Symbol	Dimensions In Millimeters		Dimensions In Inches	
	Min	Max	Min	Max
A	1.050	1.250	0.041	0.049
A1	0.000	0.100	0.000	0.004
A2	1.050	1.150	0.041	0.045
b	0.300	0.500	0.012	0.020
c	0.100	0.200	0.004	0.008
D	2.820	3.020	0.111	0.119
E	1.500	1.700	0.059	0.067
E1	2.650	2.950	0.104	0.116
e	0.950(BSC)		0.037(BSC)	
e1	1.800	2.000	0.071	0.079
L	0.300	0.600	0.012	0.024
θ	0°	8°	0°	8°