

## 2MHz 2A MAX Output Synchronous Step Down Converter

### ● Features

- Soft Start
- Internal Current Limit
- High Efficiency – Up to 95%
- Very Low Quiescent Current of 40uA
- MAX 2A Output Current at Vin=3V
- 2MHz Constant Frequency Operation
- Internal Synchronous Rectifier Eliminates Schottky Diode
- Adjustable Output Voltages From 0.6V to VIN
- Fixed Output Voltage Options Available
- 100% Duty Cycle Low-Dropout Operation
- 0.1uA Shutdown Current
- Tiny SOT23-6L Package

### ● Applications

- Blue Tooth Headsets
- Portable Audio Players
- Mobile Phones
- Wireless and DSL Modems
- Digital Cameras
- Portable Instruments

### ● General Description

The FS1403 is a fixed-frequency current-modes Synchronous PWM step down converter that is capable of delivering MAX 2A of output current while achieving peak efficiency of 95%. Under light load conditions, the FS1403 operates in a proprietary pulse skipping mode that consumes just 40uA of supply current, maximizing battery life in portable applications. The FS1403 operates with a fixed frequency of 2MHz, minimizing noise in noise-sensitive applications and allowing the use of small external components. The FS1403 is an ideal solution for applications powered by Li-Ion batteries or other portable applications that require small board space.

The FS1403 is available in an adjustable output voltage version capable of generating output voltage version from 0.6V to VIN. The FS1403 is available in the tiny 6-pin SOT23-6L package.

### ● Pin Configurations

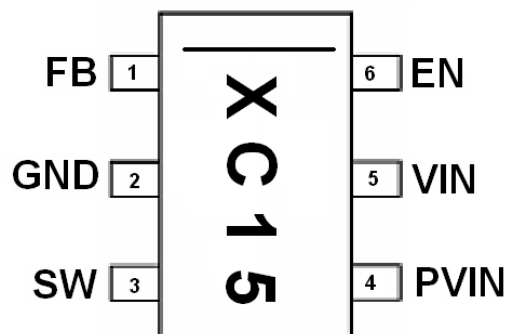

**FS1403 / SOT26L**

# FS1403

## ● Absolute Maximum Ratings

Parameter	Symbol	Ratings	Unit
IN Pin Voltage	V <sub>IN</sub>	-0.3 to 7V	V
FB Pin Voltage	V <sub>FB</sub>	-0.3 to 7V	V
EN Pin Voltage	V <sub>EN</sub>	-0.3 to 7V	V
SW Pin Voltage	V <sub>sw</sub>	-0.3 to V <sub>IN</sub> + 0.3	V
Continuous SW Current	I <sub>sw</sub>	Internally limited	A
Maximum Power Dissipation (derate 5.3mW/°C above T <sub>A</sub> =50°C )	P <sub>D</sub>	530	mW
Operating Junction Temperature	T <sub>opr</sub>	-40 to + 150	°C
Storage Temperature Range	T <sub>stg</sub>	-55 to + 150	
Lead Temperature (Soldering, 10 seconds)	T <sub>solder</sub>	300	

## ● Electrical Characteristics

( V<sub>IN</sub>=V<sub>EN</sub>=3.6V, T<sub>A</sub>= 25°C C<sub>in</sub>=4.7uF C<sub>out</sub>=10uF all capacitors are ceramic, unless otherwise specified.)

Parameter	Symbol	Conditions	Min	Typ	Max	Units
Input Voltage Range	V <sub>IN</sub>		2.5		6.5	V
Under Voltage Lockout Threshold	V <sub>UVLO</sub>	V <sub>IN</sub> rising, hysteresis =0.1V	2.25	2.4	2.5	V
Operating Supply Current		V <sub>FB</sub> =60%, I <sub>OUT</sub> =0	--	586	--	uA
Standby Supply Current		V <sub>FB</sub> =105%, I <sub>OUT</sub> =0	--	33	40	uA
Shutdown Supply Current		V <sub>EN</sub> =0V, V <sub>IN</sub> =4.2V	--	0.1	5	uA
Adjustable Version Regulation Voltage	V <sub>FB</sub>	T <sub>A</sub> =25°C	0.591	0.6	0.609	V
		0°C<T <sub>A</sub> <85°C	0.588	0.6	0.612	V
		-40°C<T <sub>A</sub> <85°C	0.582	0.6	0.618	V
Output Voltage Line Regulation		V <sub>IN</sub> =3V to 5V	--	0.016	0.4	%/V
Output Voltage Load Regulation		I <sub>out</sub> =10mA to 1500mA	--	1	--	%
Inductor Current Limit	I <sub>LIM</sub>	V <sub>IN</sub> =3.0V, V <sub>FB</sub> =90% of V <sub>out(NOM)</sub>	--	2.5	--	A
Oscillator Frequency	f <sub>sw</sub>	V <sub>FB</sub> or V <sub>OUT</sub> in regulation		2		MHz
PMOS On Resistance	R <sub>ONP</sub>	I <sub>sw</sub> =-100mA	--	0.25	--	Ω
NMOS On Resistance	R <sub>ONN</sub>	I <sub>sw</sub> =100mA	--	0.23	--	Ω
SW Leakage Current		EN=GND, V <sub>IN</sub> =5.5V V <sub>sw</sub> =5.5V	--	--	1	uA
EN Logic High Threshold	V <sub>IH</sub>	V <sub>IN</sub> =2.7V to 5.5V	1.4	--	--	V
EN Logic Low Threshold	V <sub>IL</sub>	V <sub>IN</sub> =2.7V to 5.5V			0.4	V
EN Input Bias Current	I <sub>EN</sub>	V <sub>IN</sub> =5.5V, EN=GND or IN		0.01	0.1	uA

# FS1403

- Typical Block Diagram

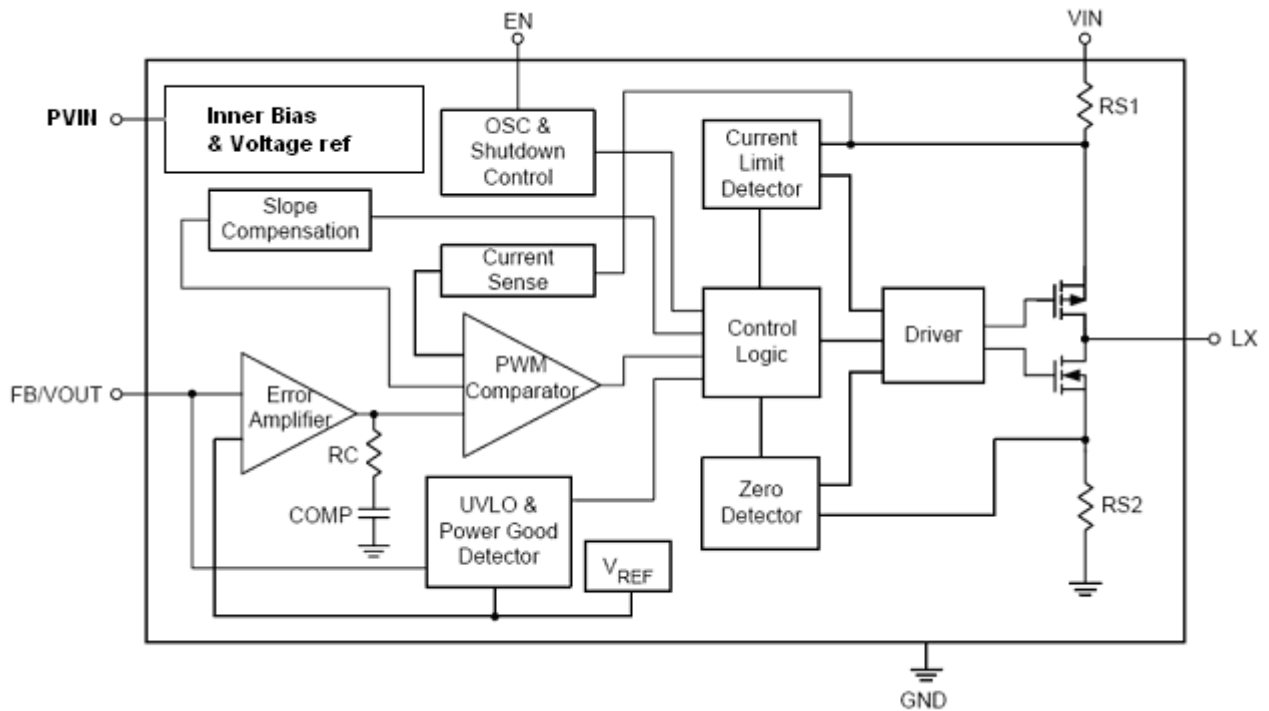

- Pin Description

FS1403 -①②③④

DESIGNATOR	SYMBOL	DESCRIPTION
①②	Output Detection Voltage	AD=ADJ
③④	Package Type:	SL: SOT23-6L

Pin	Pin Name	Pin Description
1	FB	Feedback Node. For fixed output voltage options, connects this pin directly to the output. For the Adjustable output version the voltage at this pin is regulated to 0.6V; connect to this pin to the center of the output voltage feedback network.
2	GND	Ground.
3	SW	Switching Node Output. Connect this pin to the switching end of the inductor.
4	PVIN	Input supply pin for power FET.
5	VIN	Power Input. Bypass to GND as close as possible to the IC with a high quality ceramic capacitor.
6	EN	Enable Control Input. Drive EN to IN or to a logic high for normal operation, drive to GND or a logic low to disable the regulator.

# FS1403

## Application Information

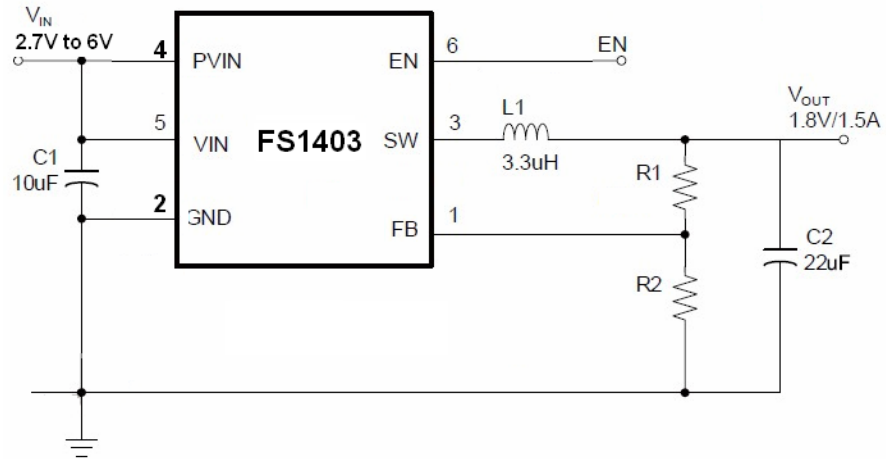

### Application note:

- 1、 Inductor Value (Table 1)

Table 1. Typical Inductor Values

V <sub>OUT</sub>	0.6V to 0.9V	0.9V to 1.8V	>1.8V
L	1.5uH	2.2uH	2.7uH

- 2、 C<sub>in</sub>=4.7uF(ceramic capacitor).
- 3、 C<sub>out</sub>=10uF(ceramic capacitor).
- 4、 Output Voltage Programming

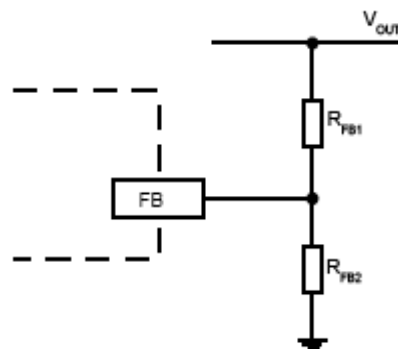

Figure 1. Output Voltage Programming

Figure 1 shows the Feedback network necessary to set the output voltage when the adjustable version is used. Select the proper ratio of the two feedback resistors  $R_{FB1}$  and  $R_{FB2}$  based on the desired output voltage. Typically choose  $R_{FB2} \approx 100K\Omega$  and determine  $R_{FB1}$  from the output voltage:

$$R_{FB1} = R_{FB2} \left( \frac{V_{OUT}}{0.6V} - 1 \right)$$

Connect a small capacitor across  $R_{FB1}$  for feed forward capacitance at the FB pin:

$$C_{ff} = 2 \times 10^{-5} / R_{FB1}$$

# FS1403

where  $R_{FB1}=900K\ \Omega$  use 22pF. When using very low ESR output capacitors, such as ceramic, check for stability while examining load-transient response, and increase the compensation capacitor C1 if needed.

## 5、Dropout Operation

As the input supply voltage decreases to a value approaching the output voltage, the duty cycle increases toward the maximum on-time. Further reduction of the supply voltage forces the main switch to remain on for more than one cycle until it reaches 100% duty cycle. Possible occurred larger ripple on the low-dropout operation. Recommended operating voltage  $V_{IN} \geq V_{OUT} + 0.7V$

## PCB layout caution

- 1、 The power traces, consisting of the GND trace, the SW trace and the Vin trace should be keep short,direct and wide.
- 2、 Vfb should be connected directly to the feedback resistors, The resistive divider R1/R2 must connected between the (+) plate of Cout and ground.
- 3、 The (+) plate of Cin should be connected to Vin as closely as possible, because this capacitor provides the AC current to the internal power MOSFETS.
- 4、 Keep the switching node SW away form the sensitive Vfb node
- 5、 Keep the (-) plates of Cin and Cout as close as possible
- 6、 The high current paths
- 7、 The recommended PCB layout

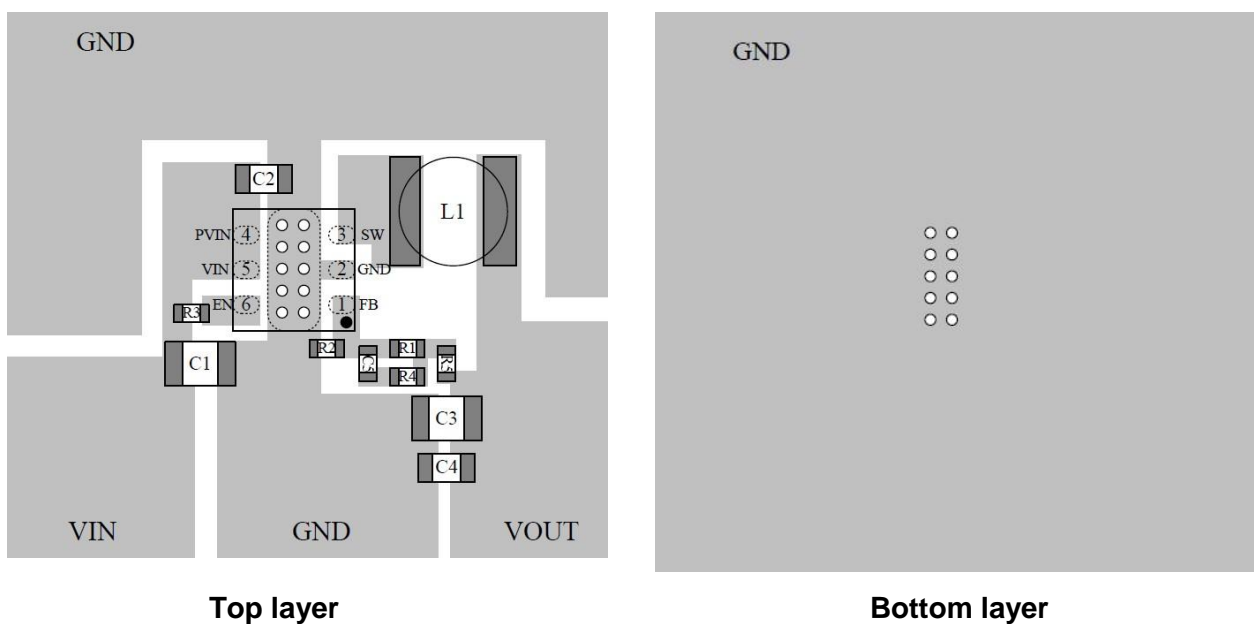

# FS1403

## ● Typical Performance Characteristics

For FS1403

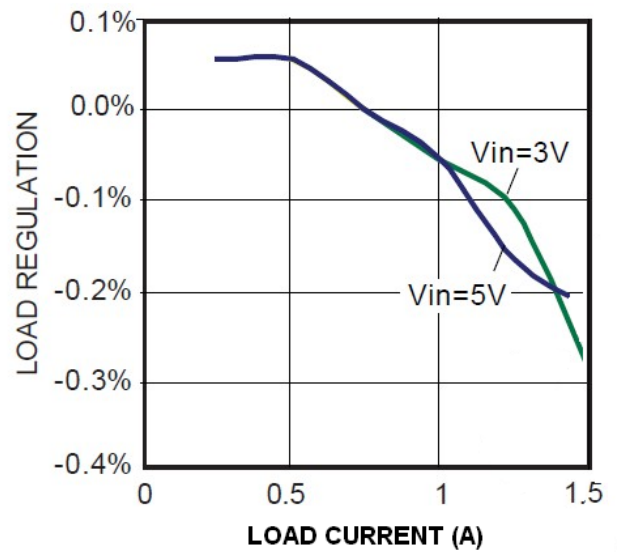
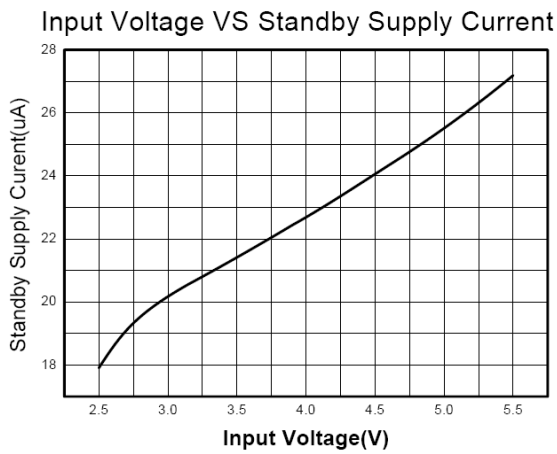
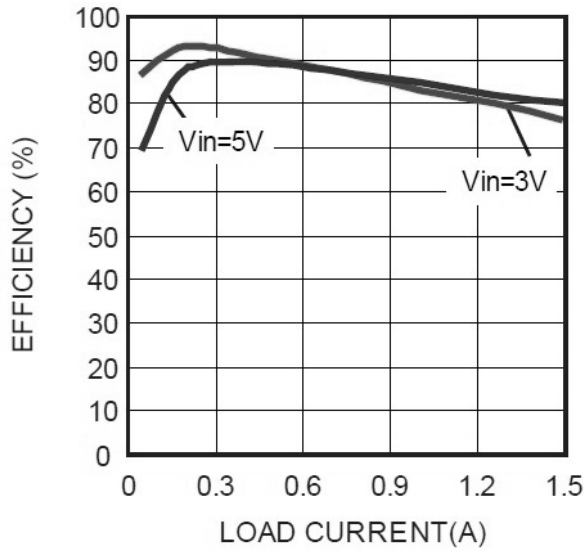

# FS1403

- Package Information

## SOT23-5L

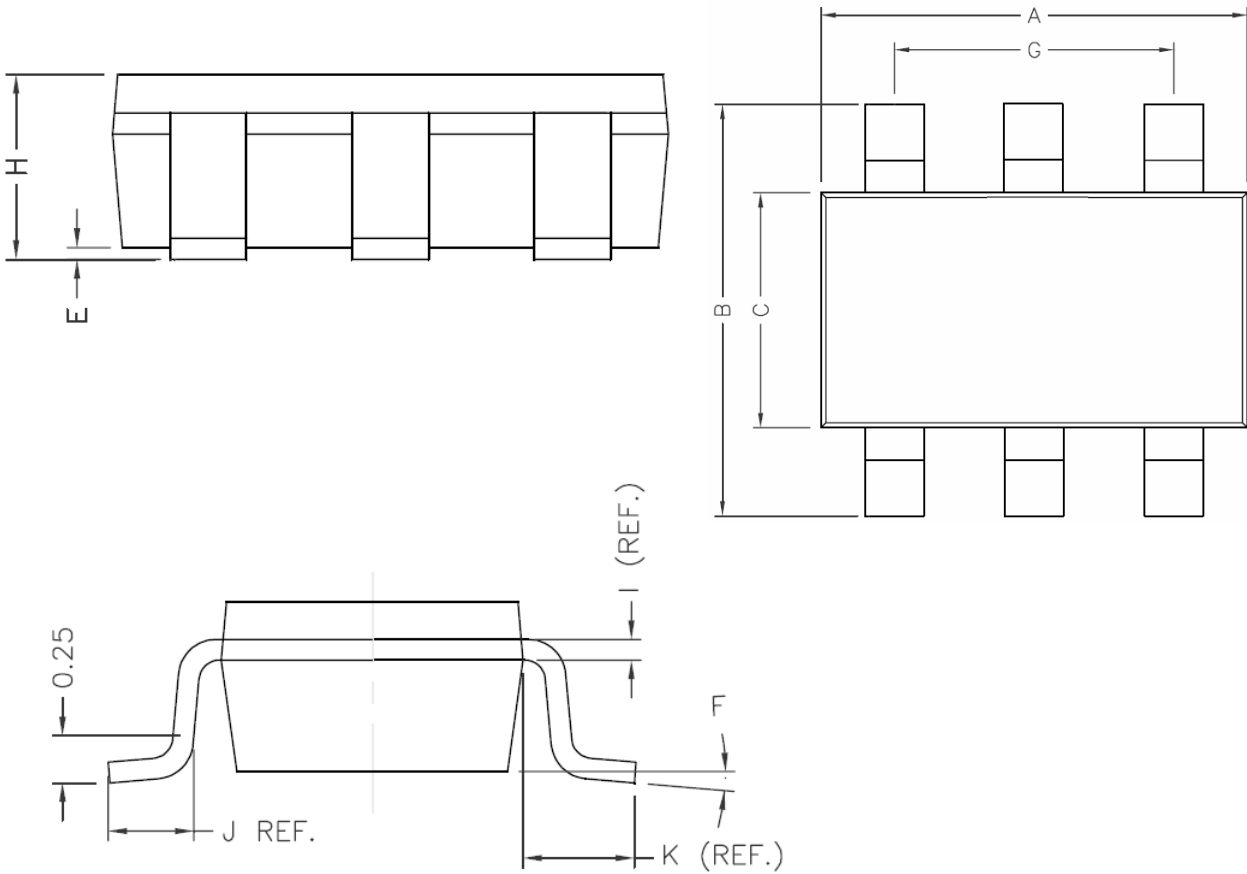

REF.	Millimeter		REF.	DIMENSIONS
	Min.	Max.		Millimeter
A	2.70	3.10	G	1.90 REF.
B	2.60	3.00	H	1.10 MAX.
C	1.40	1.80	I	0.12 REF.
D	0.30	0.55	J	0.45 REF.
E	0	0.10	K	0.60 REF.
F	0°	10°	L	0.95 REF.