

## 2A, 27V, 340 kHz Synchronous Rectified Step-Down

- Features**

- 2A Output Current
- Wide 4.5V to 27V Operating Input Range
- Integrated 100mΩ Power MOSFET Switches
- Output Adjustable from 0.925V to 0.8Vin
- Up to 96% Efficiency
- Programmable Soft-Start
- Stable with Low ESR Ceramic Output Capacitors
- Fixed 340KHz Frequency
- Cycle-by-Cycle Over Current Protection
- Input Under Voltage Lockout

- Applications**

- TFT LCD Monitors
- Portable DVDs, Headphones, MP3 Players, etc.
- Car-Powered or Battery-Powered Equipment
- Set-Top Boxes
- Telecom Power Supplies
- DSL and Cable Modems and Routers

- Typical Application**

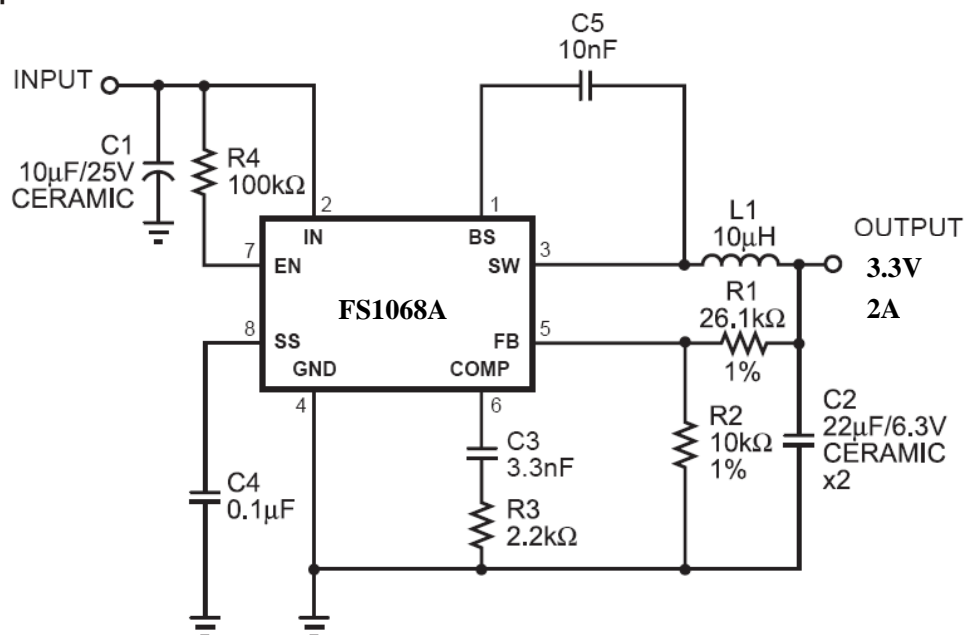

- General Description**

The FS1068A is a monolithic synchronous buck regulator. The device integrates 100mΩ MOSFETS that provide 3A continuous load current over a wide operating input voltage of 4.5V to 27V. Current mode control provides fast transient response and cycle-by-cycle current limit. An adjustable soft-start prevents inrush current at turn-on. In shutdown mode, the supply current drops below 1 µA. This device, available in an 8-pin SOIC package, provides a very compact system solution with minimal reliance on external components.

- Package Information**

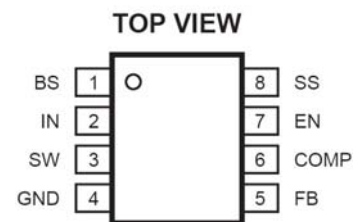

# FS1068A

## ● PIN DESCRIPTIONS

Pin	Name	Description
1	BS	High-Side Gate Drive Boost Input. BS supplies the drive for the high-side N-Channel MOSFET switch. Connect a 0.01 $\mu$ F or greater capacitor from SW to BS to power the high side switch.
2	IN	Power Input. IN supplies the power to the IC, as well as the step-down converter switches. Drive IN with a 4.5V to 27V power source. Bypass IN to GND with a suitably large capacitor to eliminate noise on the input to the IC. See Input Capacitor.
3	SW	Power Switching Output. SW is the switching node that supplies power to the output. Connect the output LC filter from SW to the output load. Note that a capacitor is required from SW to BS to power the high-side switch.
4	GND	Ground.
5	FB	Feedback Input. FB senses the output voltage to regulate that voltage. Drive FB with a resistive voltage divider from the output voltage. The feedback threshold is 0.925V. See Setting the Output Voltage.
6	COMP	Compensation Node. COMP is used to compensate the regulation control loop. Connect a series RC network from COMP to GND to compensate the regulation control loop. In some cases, an additional capacitor from COMP to GND is required. See Compensation Components.
7	EN	Enable Input. EN is a digital input that turns the regulator on or off. Drive EN high to turn on the regulator, drive it low to turn it off. Pull up with 100k $\Omega$ resistor for automatic startup.
8	SS	Soft-Start Control Input. SS controls the soft start period. Connect a capacitor from SS to GND to set the soft-start period. A 0.1 $\mu$ F capacitor sets the soft-start period to 15ms. To disable the soft-start feature, leave SS unconnected.

## ● Functional Block Diagram

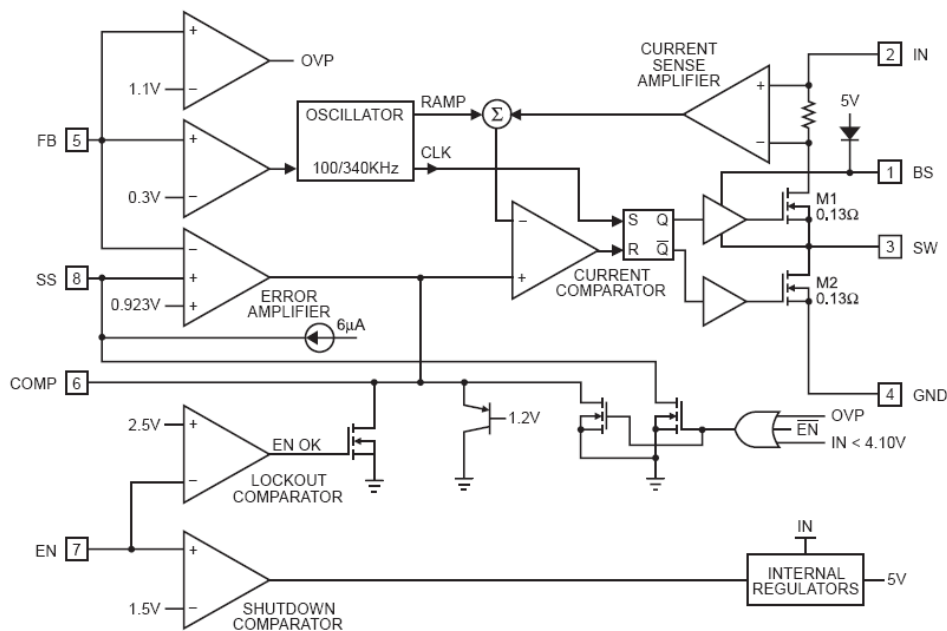

Figure 1—Functional Block Diagram

# FS1068A

● **Absolute Maximum Ratings @ $T_A=25^\circ\text{C}$**  unless otherwise noted

PARAMETER	SYMBOL	TYP
Supply Voltage	VIN	-0.3V to +30V
Switch Node Voltage	VSW	-1V to +30V
Boost Voltage	VBS	VSW - 0.3V to VSW + 6V
All Other Pins		-0.3V to +6V
Junction Temperature.		150°C
Lead Temperature		260°C
Storage Temperature		-65°C to +150°C
Recommended Operating Conditions		
Input Voltage	VIN	4.5V to 27V
Output Voltage	VOUT	0.923V to 20V
Ambient Operating Temperature		-40°C to +85°C
Thermal Resistance (3)	$\theta_{JA}$ $\theta_{JC}$	90..... 45... ° C/W

● **Electrical Characteristics @ $T_A=25^\circ\text{C}$**  unless otherwise noted

VIN = 12V, TA = +25°C, unless otherwise noted.

Parameter	Symbol	Condition	Min	Typ	Max	Units
Shutdown Supply Current		VEN = 0V		0.3	3.0	$\mu\text{A}$
Supply Current		VEN = 2.0V; VFB = 1.0V		1.3	1.5	mA
Feedback Voltage	VFB	4.75V $\leq$ VIN $\leq$ 18V	0.900	0.923	0.946	V
Feedback Overvoltage Threshold				1.1		V
Error Amplifier Voltage Gain (4)	AEA			400		V/V
Error Amplifier Transconductance	GEA	$\Delta \text{IC} = \pm 10\mu\text{A}$		820		$\mu\text{A/V}$
High-Side Switch On Resistance (4)	RDS(ON)1			85		m $\Omega$
Low-Side Switch On Resistance (4)	RDS(ON)2			85		m $\Omega$
High-Side Switch Leakage Current		VEN = 0V, VSW = 0V		0	10	$\mu\text{A}$
Upper Switch Current Limit		Minimum Duty Cycle	2.7	3.5		A
Lower Switch Current Limit		From Drain to Source		0.9		A
COMP to Current Sense Transconductance	GCS			5.2		A/V
Oscillation Frequency	Fosc1			340		KHz
Short Circuit Oscillation Frequency	Fosc2	VFB = 0V		110		KHz
Maximum Duty Cycle	DMAX	VFB = 1.0V		90		%
Minimum On Time (4)				220		ns
EN Shutdown Threshold Voltage		VEN Rising	1.1	1.5	2.0	V
EN Shutdown Threshold Voltage Hysteresis				220		mV
EN Lockout Threshold Voltage			2.2	2.5	2.7	V
EN Lockout Hysteresis				210		mV

# FS1068A

Input Under Voltage Lockout Threshold		VIN Rising	3.80	4.05	4.40	V
Hysteresis				210		mV
Soft-Start Current		VSS = 0V		6		μA
Soft-Start Period		CSS = 0.1μF		15		ms
Thermal Shutdown (4)				160		°C

**Note:** 4) Guaranteed by design, not tested.

## ● Typical Performance Characteristics

(VIN = 12V, VO = 3.3V, L = 10μH, C1 = 10μF, C2 = 22μF, TA = +25°C, unless otherwise noted.)

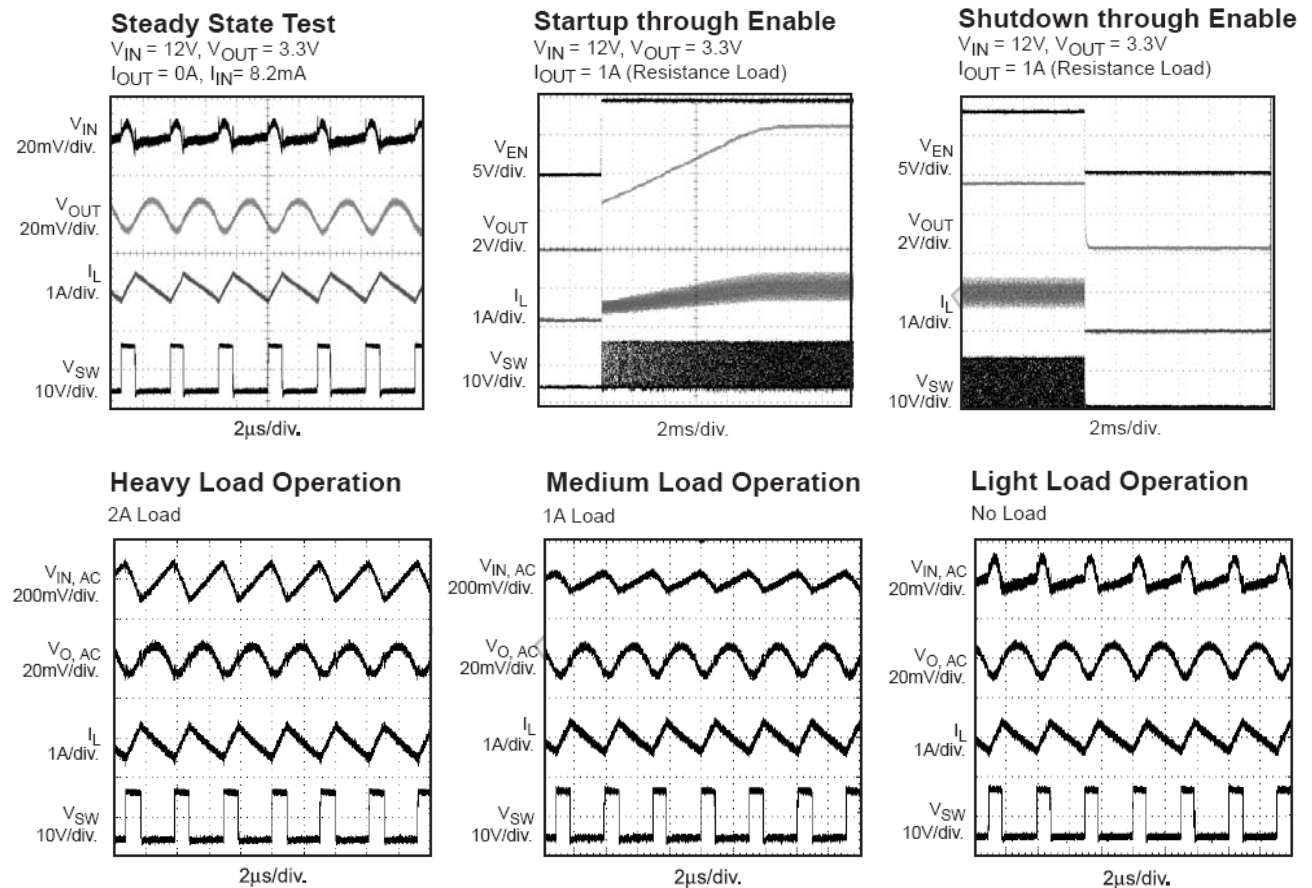

# FS1068A

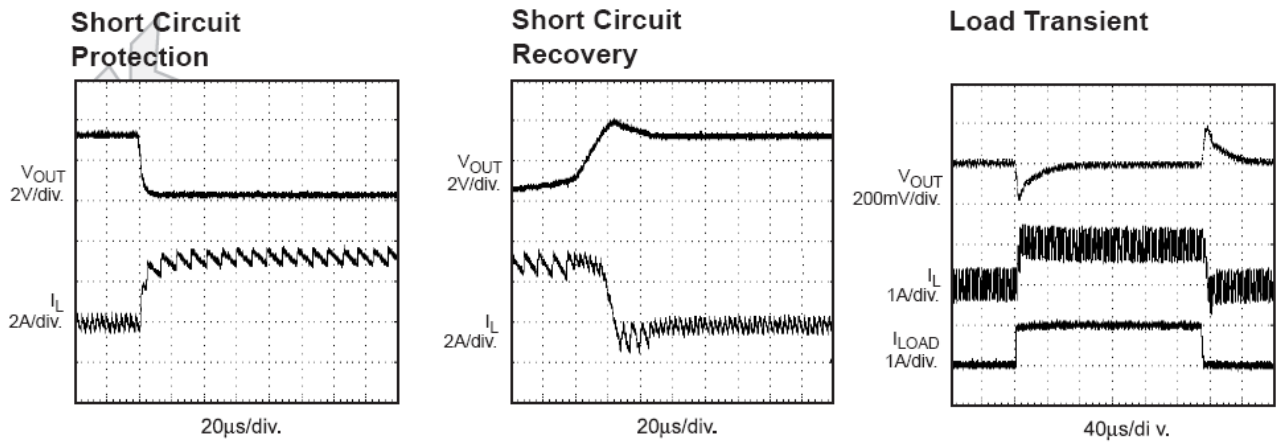

## OPERATION

### FUNCTIONAL DESCRIPTION

The FS1068A is a synchronous rectified, current-mode, step-down regulator. It regulates input voltages from 4.5V to 27V down to an output voltage as low as 0.925V, and supplies up to 2A of load current.

The FS1068A uses current-mode control to regulate the output voltage. The output voltage is measured at FB through a resistive voltage divider and amplified through the internal transconductance error amplifier. The voltage at the COMP pin is compared to the switch current measured internally to control the output voltage.

The converter uses internal N-Channel MOSFET switches to step-down the input voltage to the regulated output voltage. Since the high side MOSFET requires a gate voltage greater than the input voltage, a boost capacitor connected between SW and BS is needed to drive the high side gate. The boost capacitor is charged from the internal 6V rail when SW is low.

When the FS1068A FB pin exceeds 20% of the nominal regulation voltage of 0.925V, the over voltage comparator is tripped and the COMP pin and the SS pin are discharged to GND, forcing the high-side switch off.

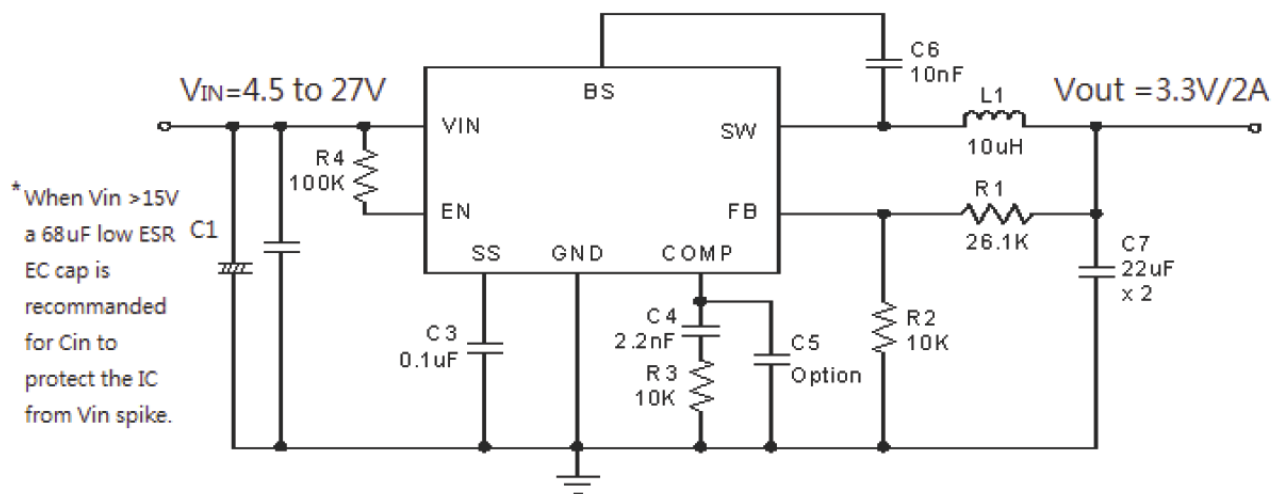

FS1068A 3.3V/2A output

# FS1068A

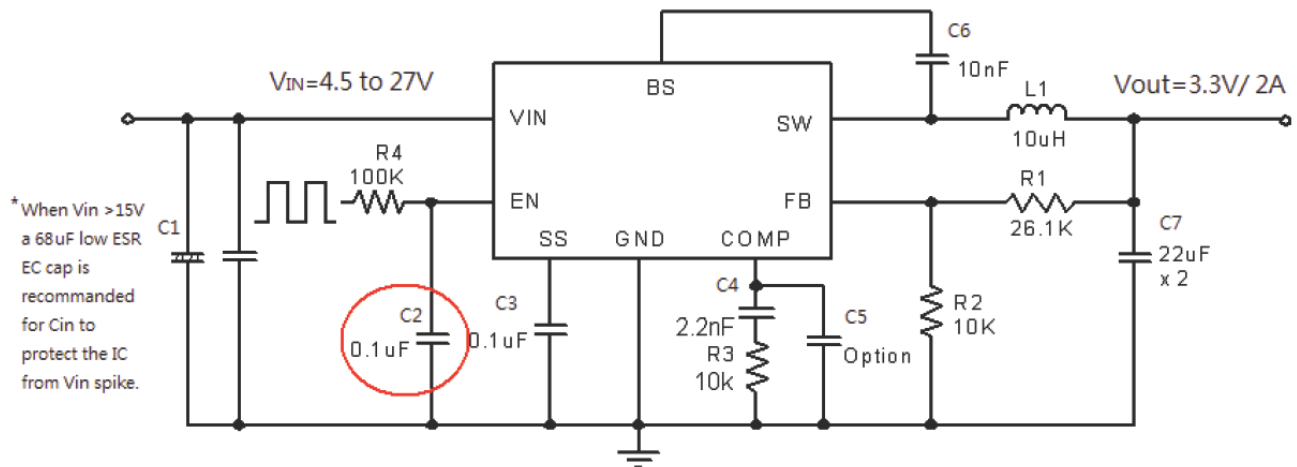

FS1068A Circuit, 3.3V/2A output with EN function

Note: C2 is required for separate EN signal

**Table1 – Recommended Resistance Values**

VOUT	R1	R2
1.0V	1.0 KΩ	12 KΩ
1.2V	3.0 KΩ	10 KΩ
1.8V	9.53 KΩ	10 KΩ
2.5V	16.9 KΩ	10 KΩ
3.3V	26.1 KΩ	10 KΩ
5V	44.2 KΩ	10 KΩ
12V	121 KΩ	10 KΩ

V <sub>OUT</sub>	1.0V	1.2V	1.5V	1.8V	2.5V	3.3V	5V	9V
L	4.7uH	4.7uH	10uH	10uH	10uH	10uH	10uH	22uH

**Table 2. Typical Inductor Values**

**Table 3– Diode Selection Guide**

V <sub>in</sub> max	Part Number	Voltage/Current Rating	Vendor
<20V	B130	30V, 1A	Lite-on semiconductor corp.
<20V	SK13	30V, 1A	Lite-on semiconductor corp
>20V	B140	40V, 1A	Lite-on semiconductor corp
>20V	SK14	40V, 1A	Lite-on semiconductor corp.

# FS1068A

- **Package Information**

Physical Dimensions inches(millimeters) unless otherwise noted

### SOP8

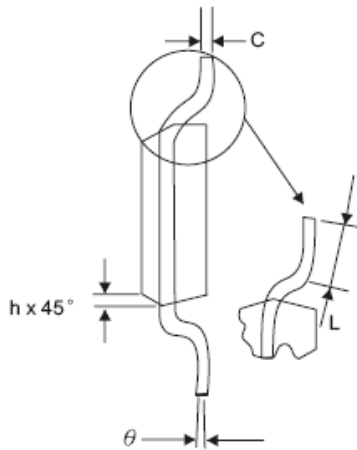
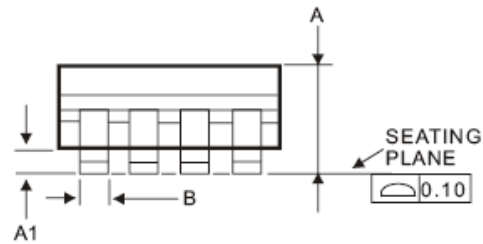
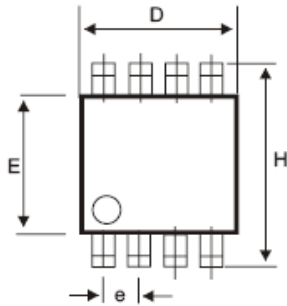

DIM	MILLIMETERS	
	MIN	MAX
A	1.35	1.75
A1	0.10	0.25
B	0.35	0.49
C	0.18	0.25
D	4.80	5.00
E	3.80	4.00
e	1.27 BSC	
H	5.80	6.20
h	0.25	0.50
L	0.40	1.25
θ	0°	7°

## IMPORTANT NOTICE

The information in this document has been carefully reviewed and is believed to be accurate. Nonetheless, this document is subject to change without notice. Team-tech assumes no responsibility for any inaccuracies that may be contained in this document, and makes no commitment to update or to keep current the contained information, or to notify a person or organization of any update. FORSEMI reserves the right to make changes, at any time, in order to improve reliability, function or design and to attempt to supply the best product possible.