

2A, 16V, 600 kHz Synchronous Rectified Step-Down

- Features**

2A Output Current
 Wide 4.5V to 16V Operating Input Range
 Integrated 130mΩ Power MOSFET Switches
 Output Adjustable from 0.6V to 15V
 Up to 95% Efficiency
 Programmable Soft-Start
 Stable with Low ESR Ceramic Output Capacitors
 Fixed 600KHz Frequency
 Cycle-by-Cycle Over Current Protection
 Input Under Voltage Lockout

- General Description**

The FS1413B is a monolithic synchronous buck regulator. The device integrates 100mΩ MOSFETS that provide 2A continuous load current over a wide operating input voltage of 4.5V to 16V. Current mode control provides fast transient response and cycle-by-cycle current limit. An adjustable soft-start prevents inrush current at turn-on. In shutdown mode, the supply current drops below 1 μA. This device, available in an 6-pin SOIC package, provides a very compact system solution with minimal reliance on external components.

- Applications**

TFT LCD Monitors
 Portable DVDs, Headphones, MP3 Players, etc.
 Car-Powered or Battery-Powered Equipment
 Set-Top Boxes
 Telecom Power Supplies
 DSL and Cable Modems and Routers

- Typical Application**

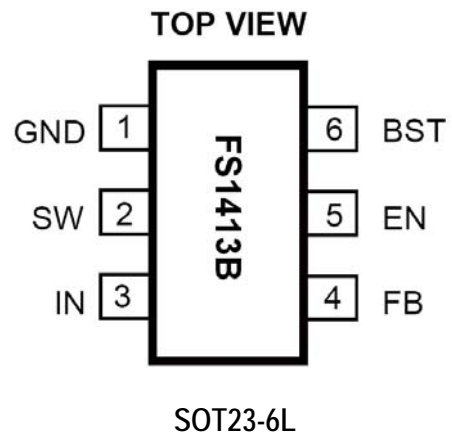
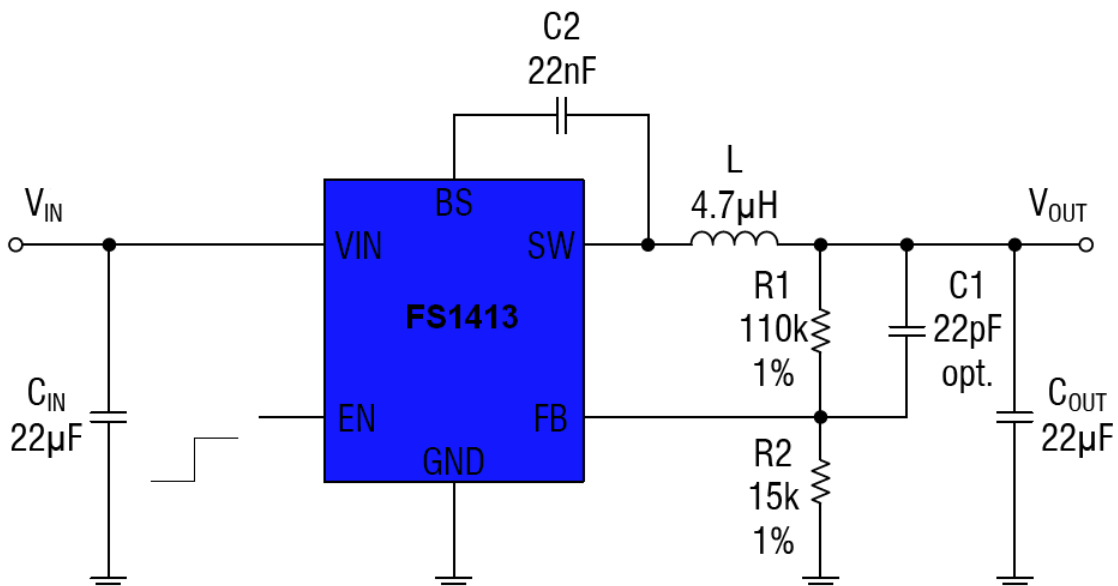

FS1413B

● PIN DESCRIPTIONS

PIN	NAME	FUNCTION
1	GND	Ground
3	VIN	Power supply Pin
2	SW	Switching Pin
4	FB	Adjustable version feedback input. Connect FB to the center point of the external resistor divider.
5	EN	Drive this pin to a logic-high to enable the IC. Drive to a logic-low to disable the IC and enter micro-power shutdown mode.
6	BST	Bootstrap. A capacitor connected between SW and BST pins is required to form a floating supply across the high-side switch driver.

● Functional Block Diagram

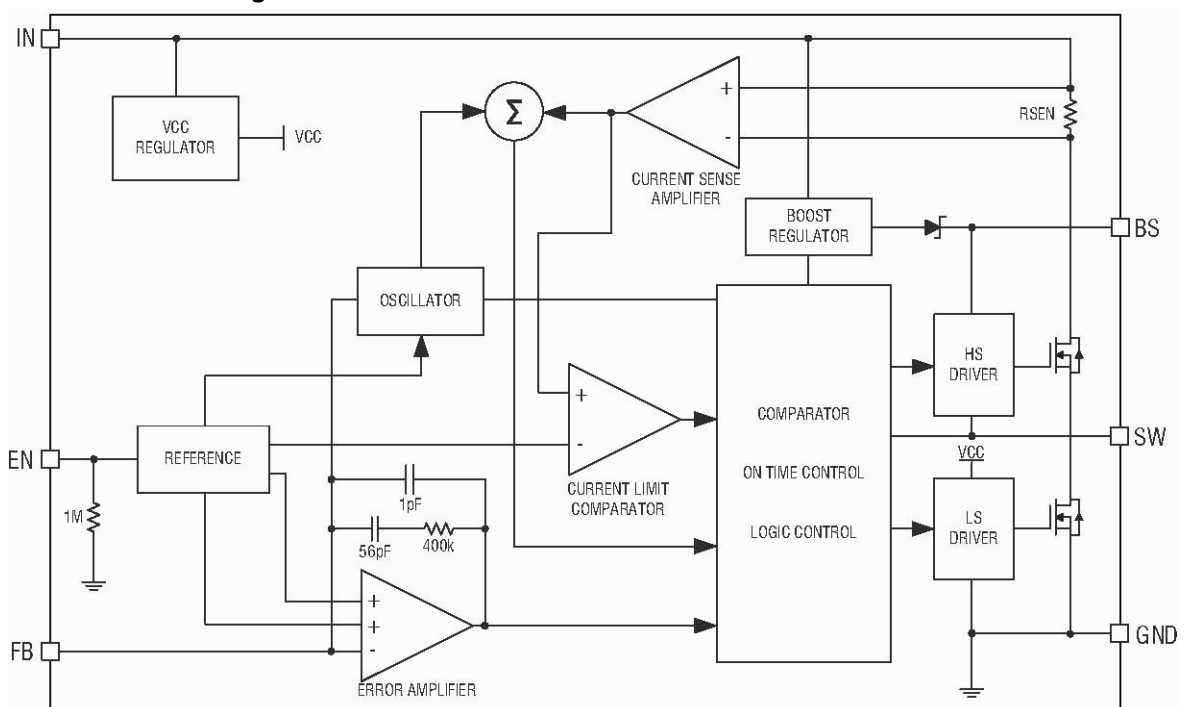

● Absolute Maximum Ratings @ $T_A=25^\circ\text{C}$ unless otherwise noted

Input Supply Voltage -0.3V to 17V
 EN,FB Voltages -0.3 to 6V
 SW Voltage -0.3V to ($V_{in}+0.5V$)
 BS Voltage ($V_{sw}-0.3$) to ($V_{sw}+5V$)

Operating Temperature Range ... -40°C to $+85^\circ\text{C}$
 Lead Temperature(Soldering, 10s) $+300^\circ\text{C}$
 Storage Temperature Range -65°C to 150°C

FS1413B

● Electrical Characteristics @ $T_A=25^\circ\text{C}$ unless otherwise noted

$V_{IN} = 12\text{V}$, $T_A = +25^\circ\text{C}$, unless otherwise noted.

Parameter	Conditions	MIN	TYP	MAX	unit
Input Voltage Range		4.5		16	V
UVLO Threshold			4.4		V
Supply Current in Operation	$V_{EN}=2.0\text{V}$, $V_{FB}=1.1\text{V}$		0.4	0.6	mA
Supply Current in Shutdown	$V_{EN}=0$ or $EN = \text{GND}$		1		μA
Regulated Feedback Voltage	$T_A = 25^\circ\text{C}$, $4.5\text{V} \leq V_{IN} \leq 18\text{V}$	0.784	0.8	0.816	V
High-Side Switch On-Resistance			90		$\text{m}\Omega$
Low-Side Switch On-Resistance			70		$\text{m}\Omega$
High-Side Switch Leakage Current	$V_{EN}=0\text{V}$, $V_{SW}=0\text{V}$		0	10	μA
Upper Switch Current Limit	Minimum Duty Cycle		3		A
Oscillation Frequency			0.6		MHz
Maximum Duty Cycle	$V_{FB}=0.6\text{V}$		92		%
Minimum On-Time			60		nS
Thermal Shutdown			160		$^\circ\text{C}$

● Typical Performance Characteristics

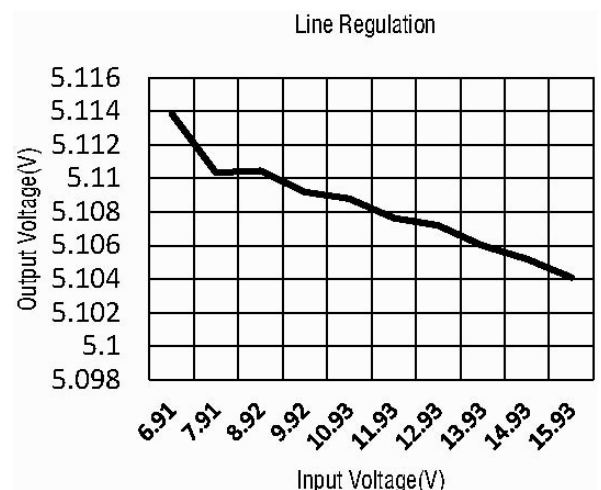
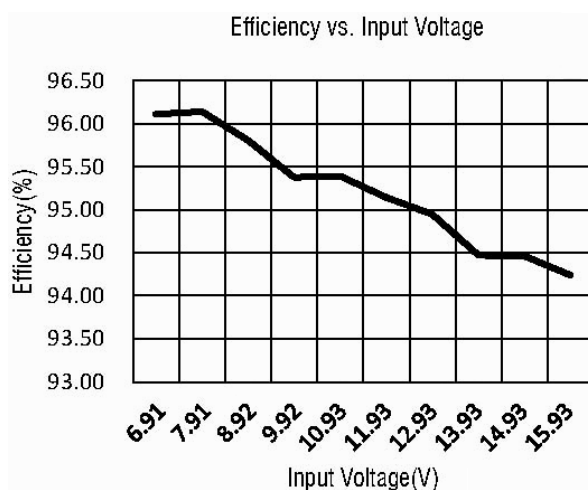
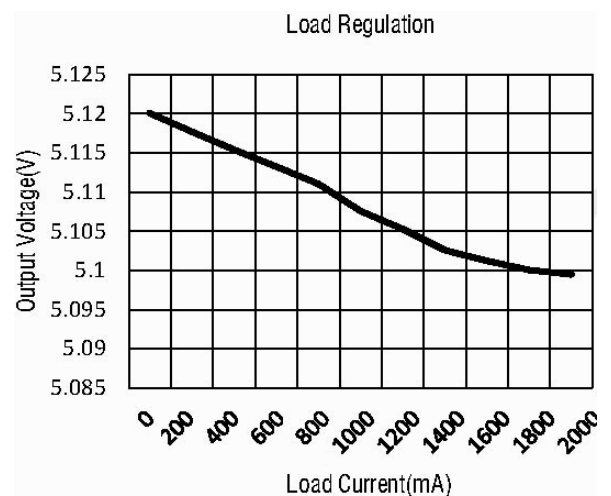
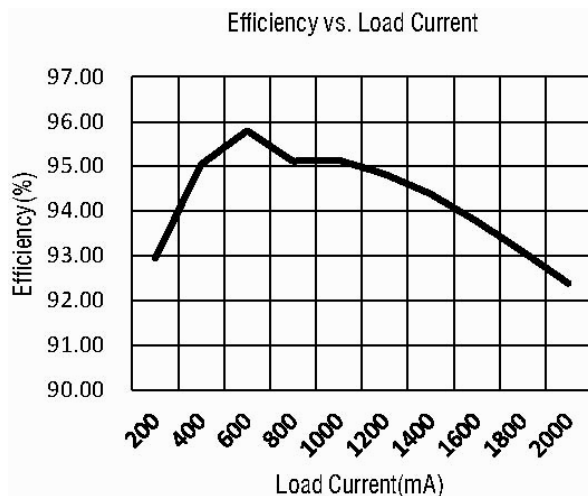

FS1413B

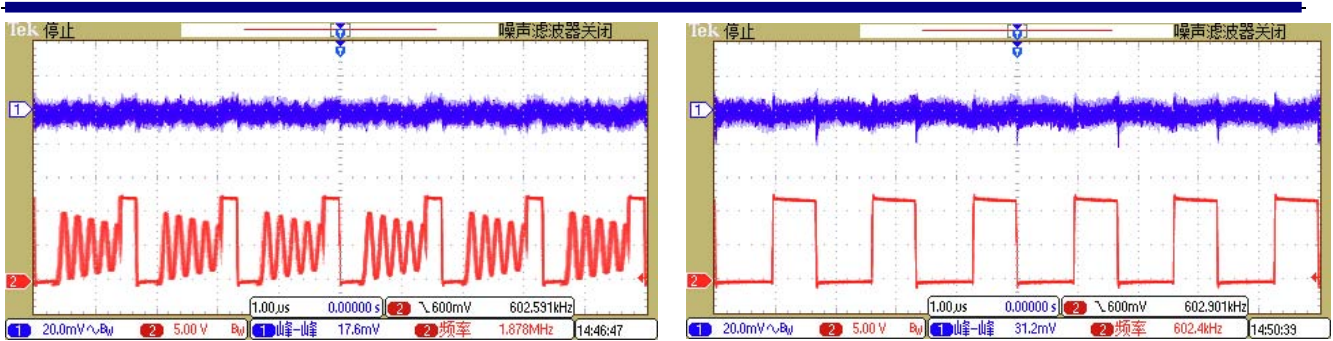

OPERATION

FUNCTIONAL DESCRIPTION

The FS1413 is a current mode step down DC/DC converter that provides excellent transient response with no extra external compensation components. This device contains an internal, low resistance, high voltage power MOSFET, and operates at a high 600K operating frequency to ensure a compact, high efficiency design with excellent AC and DC performance.

Error Amplifier

The error amplifier compares the FB pin voltage with the internal FB reference (VFB) and outputs a current proportional to the difference between the two. This output current is then used to charge or discharge the internal compensation network to form the COMP voltage, which is used to control the power MOSFET current. The optimized internal compensation network minimizes the external component counts and simplifies the control loop design.

Internal Soft-Start

The soft-start is implemented to prevent the converter output voltage from overshooting during startup. When the chip starts, the internal circuitry generates a soft-start voltage (SS) ramping up from 0V to 0.6V. When it is lower than the internal reference (REF), SS overrides REF, so the error amplifier uses SS as the reference. When SS is higher than REF, REF regains control. The SS time is internally fixed to 1 ms.

Over-Current-Protection and Hiccup

The FS1413 has cycle-by-cycle over current limit when the inductor current peak value exceeds the set current limit threshold. Meanwhile, output voltage starts to drop until FB is below the Under-Voltage (UV) threshold, typically 30% below the reference. Once a UV is triggered, the FS1413 enters hiccup mode to periodically restart the part. This protection mode is especially useful when the output is dead-short to ground. The average short circuit current is greatly reduced to alleviate the thermal issue and to protect the regulator. The FS1413 exits the hiccup mode once the over current condition is removed.

Startup and Shutdown

If both VIN and EN are higher than their appropriate thresholds, the chip starts. The reference block starts first, generating stable reference voltage and currents, and then the internal regulator is enabled. The regulator provides stable supply for the remaining circuitries. Three events can shut down the chip: EN low, VIN low and thermal shutdown. In the shutdown procedure, the signaling path is first blocked to avoid any fault triggering. The COMP voltage and the internal supply rail are then pulled down. The floating driver is not subject to this shutdown command.

Setting the Output Voltage

The external resistor divider is used to set the output voltage (see Typical Application on page 1). The feedback resistor R1 also sets the feedback loop bandwidth with the internal compensation capacitor. Choose R1 to be around 100kΩ for optimal transient response. R2 is then given by:

$$R_2 = \frac{R_1}{V_{out} / V_{FB} - 1}$$

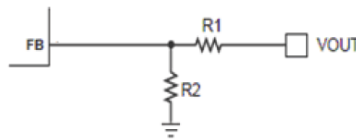

Selecting the Inductor

A 4.7μH to 22μH inductor with a DC current rating of at least 25% percent higher than the maximum load current is recommended for most applications. For highest efficiency, the inductor DC resistance should be less than 15mΩ.

Input Capacitor Selection

The input capacitor reduces the surge current drawn from the input and switching noise from the device. The input capacitor impedance at the switching frequency should be less than input source impedance to prevent high frequency switching current passing to the input. A low ESR input capacitor sized for maximum RMS current must be used. Ceramic capacitors with X5R or X7R dielectrics are highly recommended because of their low ESR and small temperature coefficients. A 22 μ F ceramic capacitor for most applications is sufficient. A large value may be used for improved input voltage filtering.

PCB Layout Guide

PCB layout is very important to achieve stable operation. It is highly recommended to duplicate EVB layout for optimum performance. If change is necessary.

- 1) Keep the path of switching current short and minimize the loop area formed by Input capacitor, high-side

MOSFET and low-side MOSFET.

- 2) Bypass ceramic capacitors are suggested to be put close to the Vin Pin.
- 3) Ensure all feedback connections are short and direct. Place the feedback resistors and compensation components as close to the chip as possible.
- 4) VOUT, SW away from sensitive analog areas such as FB.
- 5) Connect IN, SW, and especially GND respectively to a large copper area to cool the chip to improve thermal performance and long-term reliability.
- 6) A 2-layer PCB layout is recommended for most applications.