

1.5MHz 1A Synchronous Step Down Converter

- **Features**

- Soft Start
- Internal Current Limit
- High Efficiency – Up to 93%
- Very Low Quiescent Current of 24uA
- Guaranteed 1A Output Current
- 1.5MHz Constant Frequency Operation
- Internal Synchronous Rectifier Eliminates Schottky Diode
- Adjustable Output Voltages From 0.6V to V_{IN}
- Fixed Output Voltage Options Available
- 100% Duty Cycle Low-Dropout Operation
- 0.1uA Shutdown Current
- Tiny SOT23-5L Package

- **Applications**

- Blue Tooth Headsets
- Portable Audio Players
- Mobile Phones
- Wireless and DSL Modems
- Digital Cameras
- Portable Instruments

- **General Description**

The FS1402 is a fixed-frequency current-modes Synchronous PWM step down converter that is capable of delivering 1A of output current while achieving peak efficiency of 93%. Under light load conditions, the FS1402 operates in a proprietary pulse skipping mode that consumes just 24uA of supply current, maximizing battery life in portable applications. The FS1402 operates with a fixed frequency of 1.5MHz, minimizing noise in noise-sensitive applications and allowing the use of small external components. The FS1402 is an ideal solution for applications powered by Li-Ion batteries or other portable applications that require small board space.

The FS1402 is available in a variety of fixed output voltage options, 1.2V, 1.5V, 1.8V, 2.5V and is also available in an adjustable output voltage version capable of generating output voltage version from 0.6V to V_{IN} . The FS1402 is available in the tiny 5-pin SOT23-5L package.

- **Pin Configurations**

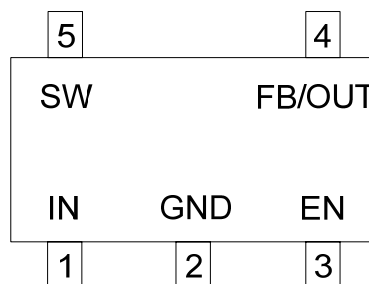

SOT23-5L

FS1402

● Absolute Maximum Ratings

Parameter	Symbol	Ratings	Unit
IN Pin Voltage	V_{IN}	-0.3 to 7V	V
FB Pin Voltage	V_{FB}	-0.3 to 7V	
EN Pin Voltage	V_{EN}	-0.3 to 7V	
SW Pin Voltage	V_{sw}	-0.3 to $V_{IN} + 0.3$	
Continuous SW Current	I_{sw}	Internally limited	A
Maximum Power Dissipation (derate 5.3mW/°C above $T_A=50^\circ\text{C}$)	P_D	530	mW
Operating Junction Temperature	T_{opr}	-40 to + 150	°C
Storage Temperature Range	T_{stg}	-55 to + 150	
Lead Temperature (Soldering, 10 seconds)	T_{solder}	300	

● Electrical Characteristics

($V_{IN}=V_{EN}=3.6\text{V}$, $T_A=25^\circ\text{C}$ $C_{IN}=4.7\mu\text{F}$ $C_{OUT}=10\mu\text{F}$ all capacitors are ceramic, unless otherwise specified.)

Parameter	Symbol	Conditions	Min	Typ	Max	Units
Input Voltage Range	V_{IN}		2.5		6.5	V
Under Voltage Lockout Threshold	V_{UVLO}	V_{IN} rising, hysteresis =0.1V	2.25	2.4	2.5	V
Operating Supply Current		$V_{FB}=60\%$, $I_{OUT}=0$	--	586	--	μA
Standby Supply Current		$V_{FB}=105\%$, $I_{OUT}=0$	--	22	33	μA
Shutdown Supply Current		$V_{EN}=0\text{V}$, $V_{IN}=4.2\text{V}$	--	0.1	5	μA
Adjustable Version Regulation Voltage	V_{FB}	$T_A=25^\circ\text{C}$	0.591	0.6	0.609	V
		$0^\circ\text{C}<T_A<85^\circ\text{C}$	0.588	0.6	0.612	V
		$-40^\circ\text{C}<T_A<85^\circ\text{C}$	0.582	0.6	0.618	V
Fixed Output Regulation voltage	V_{OUT}	FS1402-12SK	1.178	1.2	1.222	V
		FS1402-15SK	1.473	1.5	1.527	
		FS1402-18SK	1.768	1.8	1.832	
		FS1402-25SK	2.455	2.5	2.545	
Output Voltage Line Regulation		$V_{IN}=3\text{V}$ to 5V	--	0.016	0.4	%/V
Output Voltage Load Regulation		$I_{OUT}=10\text{mA}$ to 500mA	--	0.5	--	%
Inductor Current Limit	I_{LIM}	$V_{IN}=3.6\text{V}$, $V_{FB}=90\%$ of $V_{OUT(NOM)}$	--	1.4	--	A
Oscillator Frequency	f_{sw}	V_{FB} or V_{OUT} in regulation	1.2	1.5	1.8	MHz
		V_{FB} or $V_{OUT}=80\%$, of $V_{OUT(NOM)}$	--	360	--	KHz
PMOS On Resistance	R_{ONP}	$I_{sw}=-100\text{mA}$	--	0.37	0.6	Ω
NMOS On Resistance	R_{ONN}	$I_{sw}=100\text{mA}$	--	0.36	0.6	Ω
SW Leakage Current		$EN=GND$, $V_{IN}=5.5\text{V}$ $V_{sw}=5.5\text{V}$	--	--	1	μA
EN Logic High Threshold	V_{IH}	$V_{IN}=2.7\text{V}$ to 5.5V	1.4	--	--	V
EN Logic Low Threshold	V_{IL}	$V_{IN}=2.7\text{V}$ to 5.5V			0.4	V
EN Input Bias Current	I_{EN}	$V_{IN}=5.5\text{V}$, $EN=GND$ or IN		0.01	0.1	μA

FS1402

- Typical Block Diagram

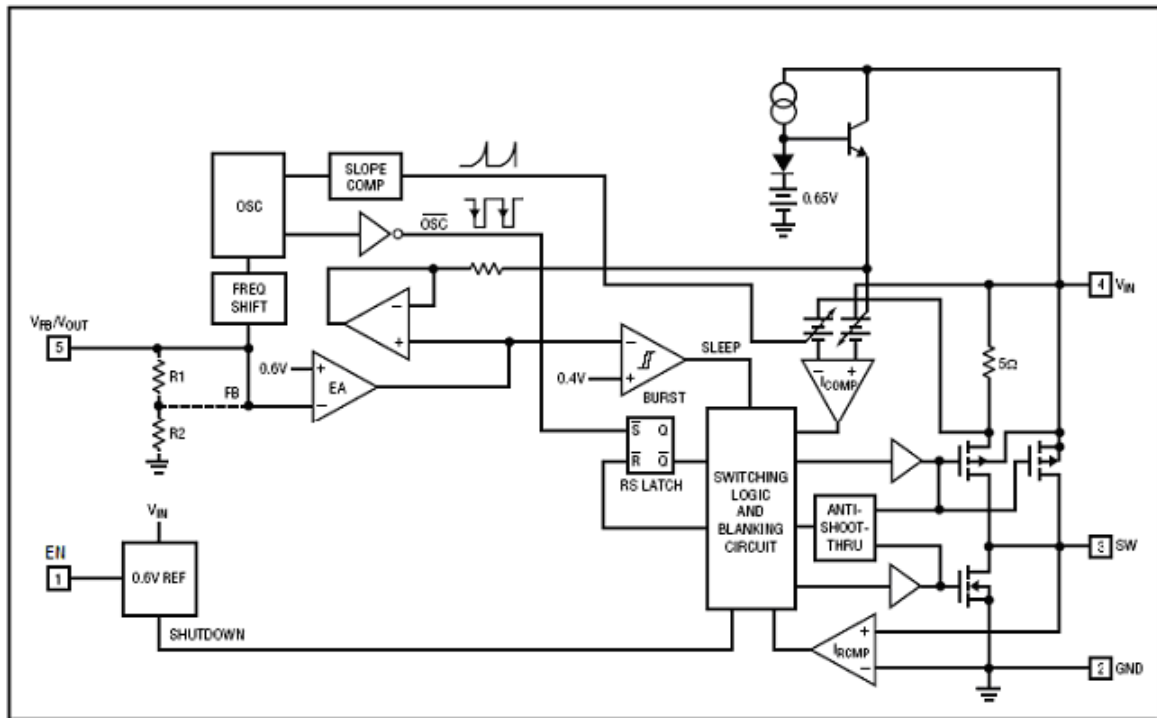

- Pin Description

FS1402-①②③④

Designator	Symbol	Description
①②	Output Detection Voltage	18=1.8V,33=3.3V, AD=ADJ
③④	Package Type:	SK: SOT23-5L

Pin Name	Pin Description
①	IN Power Input. Bypass to GND as close as possible to the IC with a high quality ceramic capacitor.
②	GND Ground.
③	EN Enable Control Input. Drive EN to IN or to a logic high for normal operation, drive to GND or a logic low to disable the regulator.
④	OUT / FB Feedback Node. For fixed output voltage options, connects this pin directly to the output. For the Adjustable output version the voltage at this pin is regulated to 0.6V; connect to this pin to the center of the output voltage feedback network.
⑤	SW Switching Node Output. Connect this pin to the switching end of the inductor.

- Application Information

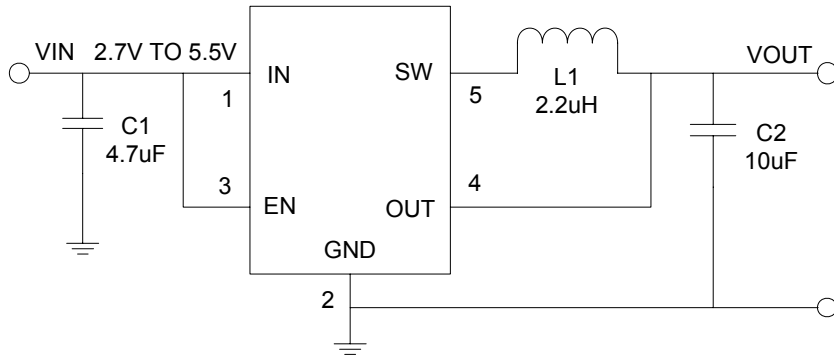

For fixed voltage

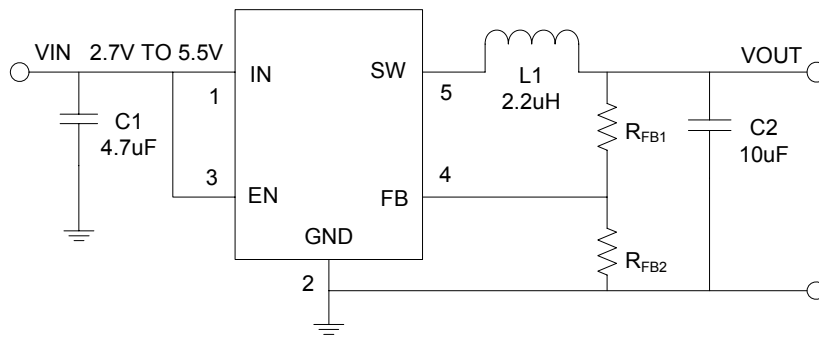

For adjustable

- Application note:

- Inductor Value (Table 1)

Table 1. Typical Inductor Values

V_{OUT}	0.6V to 0.9V	0.9V to 1.8V	>1.8V
L	1.5uH	2.2uH	2.7uH

- $C_{IN}=4.7\mu F$ (ceramic capacitor).
- $C_{OUT}=10\mu F$ (ceramic capacitor).
- Output Voltage Programming

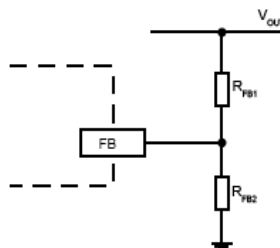

Figure 1. Output Voltage Programming

Figure 1 shows the Feedback network necessary to set the output voltage when the adjustable version is used. Select the proper ratio of the two feedback resistors R_{FB1} and R_{FB2} based on the desired output voltage. Typically choose

$R_{FB2} \approx 100K\Omega$ and determine R_{FB1} from the output voltage:

$$R_{FB1} = R_{FB2} \left(\frac{V_{OUT}}{0.6V} - 1 \right)$$

Connect a small capacitor across R_{FB1} for feed forward capacitance at the FB pin:

$$C_{ff} = 2 \times 10^{-5} / R_{FB1}$$

where $R_{FB1} = 900K\Omega$ use 22pF. When using very low ESR output capacitors, such as ceramic, check for stability while examining load-transient response, and increase the compensation capacitor C_1 if needed.

5. Dropout Operation

As the input supply voltage decreases to a value approaching the output voltage, the duty cycle increases toward the maximum on-time. Further reduction of the supply voltage forces the main switch to remain on for more than one cycle until it reaches 100% duty cycle. Possible occurred larger ripple on the low-dropout operation. Recommended operating voltage $V_{IN} \geq V_{OUT} + 0.7V$

● PCB layout caution

1. The power traces, consisting of the GND trace, the SW trace and the V_{IN} trace should be keep short, direct and wide.
2. V_{FB} should be connected directly to the feedback resistors, The resistive divider R_1/R_2 must connected between the (+) plate of C_{OUT} and ground.
3. The (+) plate of C_{IN} should be connected to V_{IN} as closely as possible, because this capacitor provides the AC current to the internal power MOSFETS.
4. Keep the switching node SW away from the sensitive V_{FB} node
5. Keep the (-) plates of C_{IN} and C_{OUT} as close as possible
6. The high current paths

- **Typical Performance Characteristics**

For FS1402A/B-1.8V

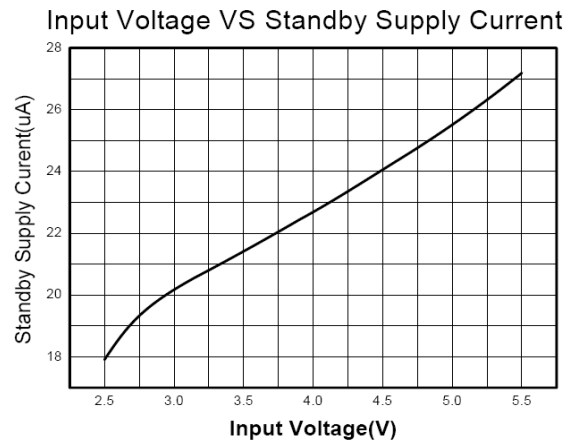
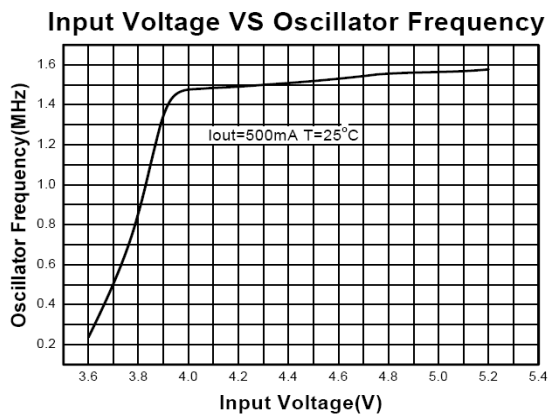
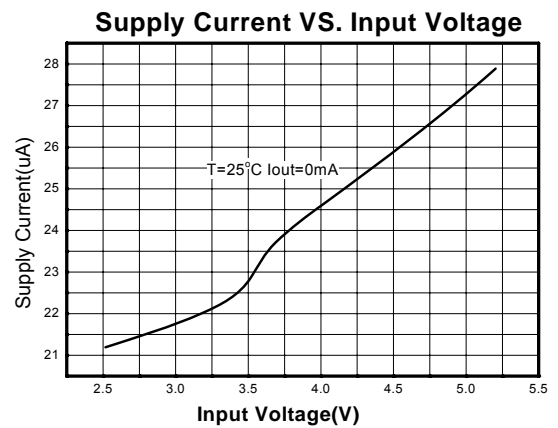
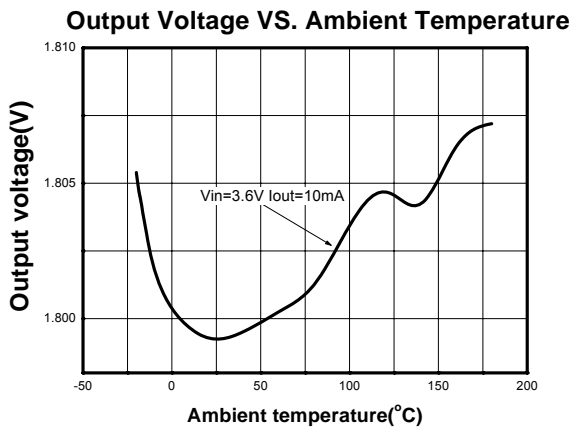
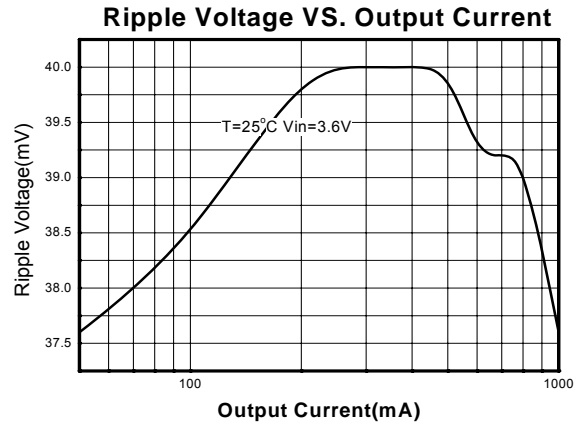
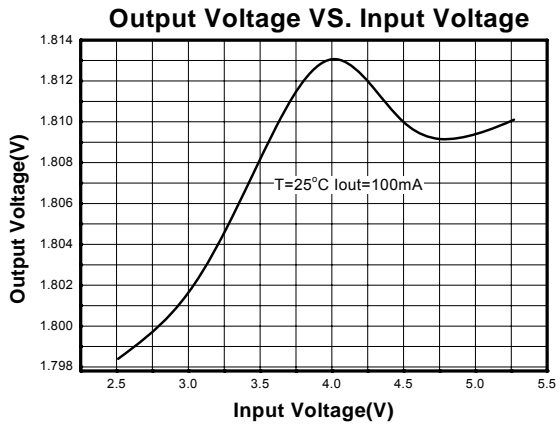

- Package Information

SOT-23-5L PACKAGE OUTLINE DIMENSIONS

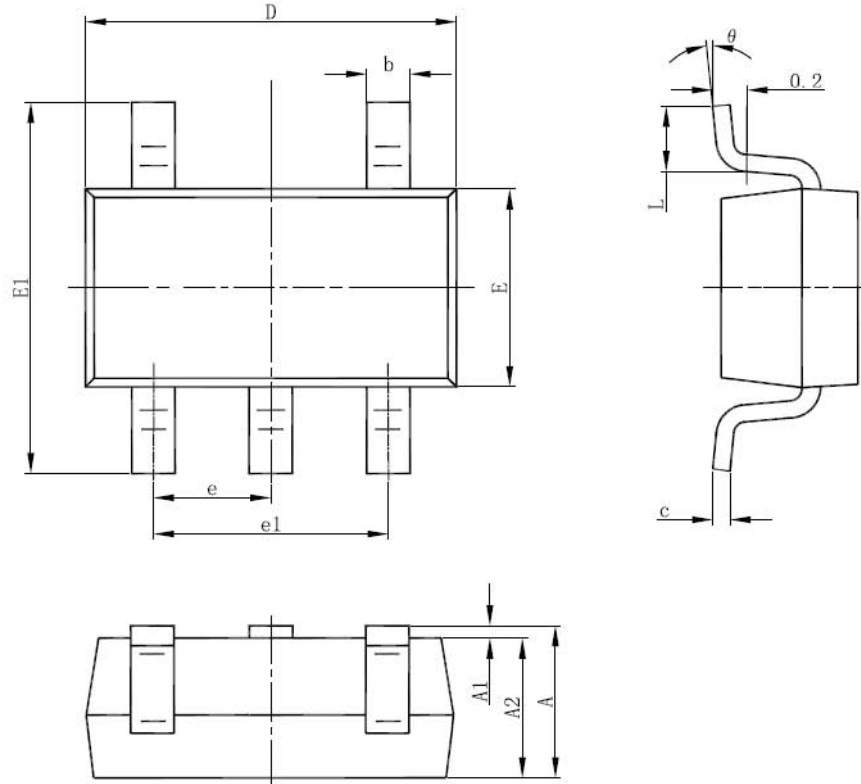

Symbol	Dimensions In Millimeters		Dimensions In Inches	
	Min	Max	Min	Max
A	1.050	1.250	0.041	0.049
A1	0.000	0.100	0.000	0.004
A2	1.050	1.150	0.041	0.045
b	0.300	0.500	0.012	0.020
c	0.100	0.200	0.004	0.008
D	2.820	3.020	0.111	0.119
E	1.500	1.700	0.059	0.067
E1	2.650	2.950	0.104	0.116
e	0.950(BSC)		0.037(BSC)	
e1	1.800	2.000	0.071	0.079
L	0.300	0.600	0.012	0.024
θ	0°	8°	0°	8°