

Simple Switcher 5A Step-Down Regulator

● Features

- adjustable output versions
- Adjustable version output range, 0.8V to 32V
- ±4% max over line and load conditions
- Available in TO263-5L package
- Guaranteed 5A output current
- Fixed 300KHz Switching Frequency
- Wide input voltage range to 32V

● Applications

- simple high-efficiency step-down regulator
- Efficient pre-regulator for linear regulators
- On-card switching regulators
- Positive to negative converter (Buck-boost)

● General Description

The FS1077 series of regulators are monolithic integrated circuits that provide all the active functions for a step-down (buck) switching regulator, capable of driving 5A load with excellent line and load regulation. These devices are available in an adjustable output version

The FS1077 series requiring a minimum number of external components, these regulators are simple to use and include internal frequency compensation and a fixed-frequency oscillator.

The PWM control circuit is able to adjust the duty ratio linearly from 0 to 100%. An enable function, an over current protection function is built inside. When short protection function happens, the operation frequency will be reduced from 300KHz to 60KHz. An internal compensation block is built in to minimize external component count.

● Pin Configurations

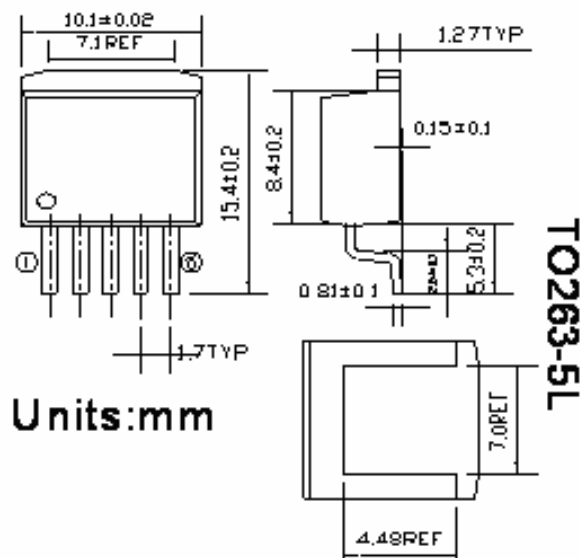

FS1077

- Pin Configuration

FS1077 (Top View)
TO263-5L

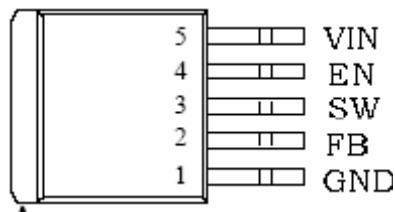

Pin Num	Pin Name	Description
1	GND	Ground Pin. Care must be taken in layout. This pin should be placed outside of the Schottky Diode to output capacitor ground path to prevent switching current spikes from inducing voltage noise into FS1077.
2	FB	Feedback Pin (FB). Through an external resistor divider network, FB senses the output voltage and regulates it. The feedback threshold voltage is 0.8V.
3	SW	Power Switch Output Pin (SW). SW is the switch node that supplies power to the output.
4	EN	Enable Pin. Drive EN pin high to turn on the device, drive it low to turn it off.
5	VIN	Supply Voltage Input Pin. FS1077 operates from a 5V to 32V DC voltage. Bypass Vin to GND with a suitably large capacitor to eliminate noise on the input.

- Typical Application

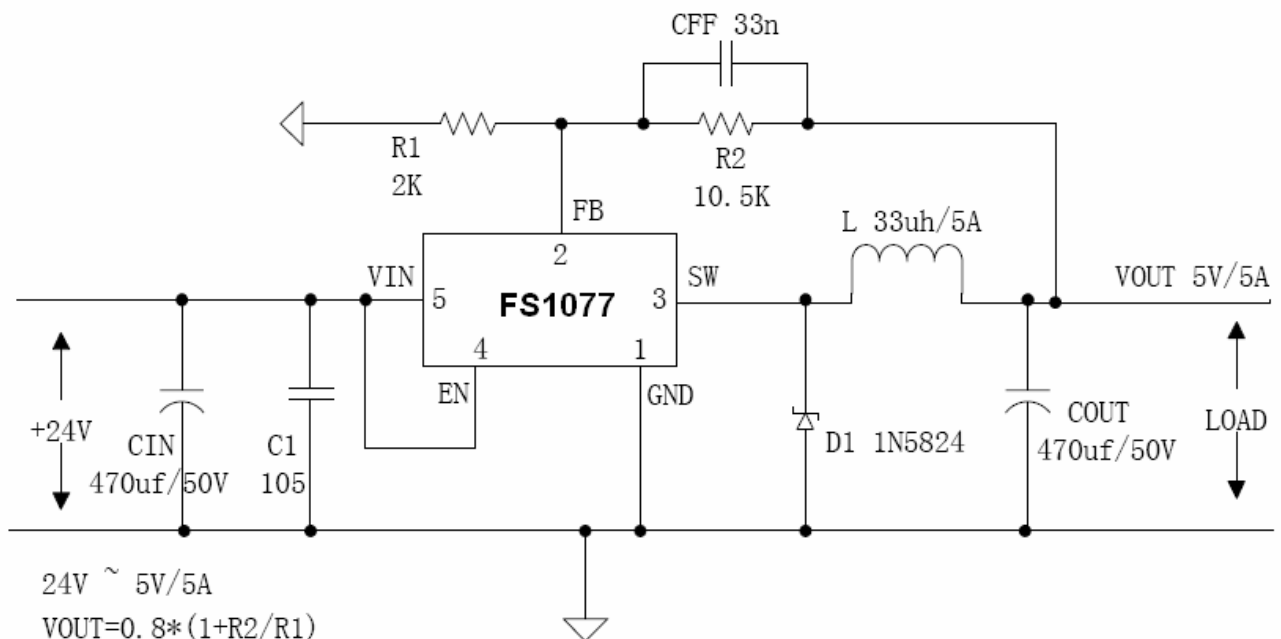

Circuit Figure 1

FS1077

● Absolute Maximum Ratings

Parameter	Symbol	Value	Unit
Input Voltage	V _{in}	-0.3 to 35	V
Feedback Pin Voltage	V _{FB}	-0.3 to V _{in}	V
EN Pin Voltage	V _{EN}	-0.3 to V _{in}	V
Output Switch Pin Voltage	V _{Output}	-0.3 to V _{in}	V
Power Dissipation	PD	Internally limited	mW
Thermal Resistance (TO263) (Junction to Ambient, No Heatsink, Free Air)	R _{JA}	30	°C/W
Operating Junction Temperature	T _J	-40 to 125	°C
Storage Temperature	T _{STG}	-65 to 150	°C
Lead Temperature (Soldering, 10 sec)	T _{LEAD}	260	°C
ESD (HBM)		2000	V

● Electrical Characteristics (DC Parameters)

V_{in} = 12V, GND=0V, V_{in} & GND parallel connect a 220uf/50V capacitor; I_{out}=500mA, T_a =25°C; the others floating unless otherwise specified.

Symbol	Parameter	Test Condition	Min.	Typ.	Max.	Unit
System parameters test circuit figure4						
V _{FB}	Feedback Voltage	V _{in} = 5V to 32V, V _{out} =5V I _{load} =0.5A to 5A	0.776	0.8	0.824	V
Efficiency	η	V _{in} =12V ,V _{out} =5V I _{out} =5A	-	90	-	%

Parameters	Symbol	Test Condition	Min.	Typ.	Max.	Unit
Input operation voltage	V _{in}		5		32	V
Shutdown Supply Current	I _{STBY}	V _{EN} =0V		60	200	uA
Quiescent Supply Current	I _q	V _{EN} =2V, V _{FB} =V _{in}		3	5	mA
Oscillator Frequency	F _{osc}		240	300	360	Khz
Switch Current Limit	I _L	V _{FB} =0		8		A
EN Pin Threshold	V _{EN}	High (Regulator ON) Low (Regulator OFF)		1.4 0.8		V
EN Pin Input Leakage Current	I _H	V _{EN} =2V (ON)		1	15	uA
	I _L	V _{EN} =0V (OFF)		1	15	uA
Max. Duty Cycle	D _{MAX}	V _{FB} =0V		100		%

FS1077

- **Test Circuit and Layout guidelines**

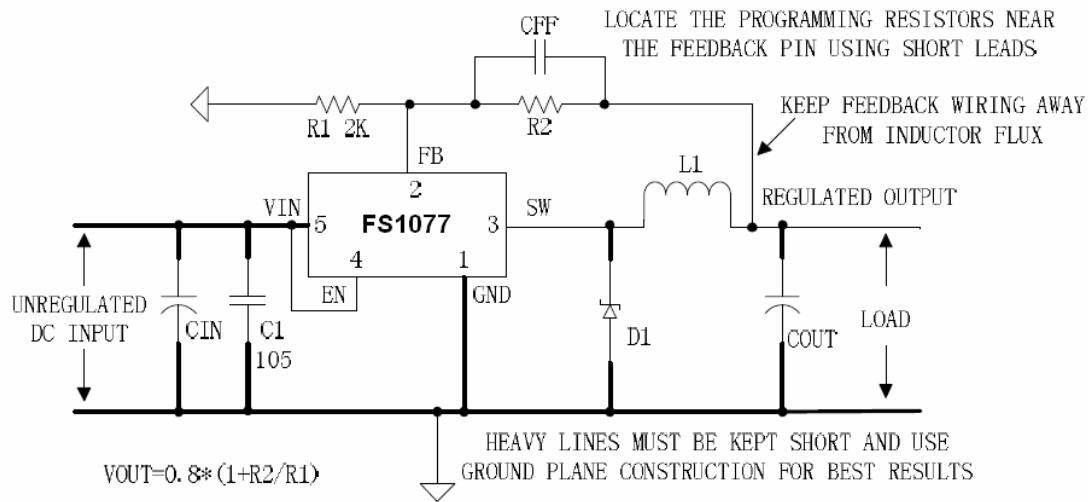

Figure. Standard Test Circuits and Layout Guides

Select R₁ to be approximately 2K, use a 1% resistor for best stability.

C₁ and C_{FF} are optional; in order to increase stability and reduce the input power line noise, C_{IN} and C₁ must be placed near to VIN and GND; For output voltages greater than approximately 10V, an additional capacitor C_{FF} is required. The compensation capacitor is typically between 100 pf and 33 nf, and is wired in parallel with the output voltage setting resistor, R₂. It provides additional stability for high output voltage, low input-output voltages, and/or very low ESR output capacitors, such as solid tantalum capacitors.

$C_{FF} = 1 / (31 * 1000 * R_2)$; This capacitor type can be ceramic, plastic, silver mica, etc. (Because of the unstable characteristics of ceramic capacitors made with Z5U material, they are not recommended.)

Schottky Diode Selection Table

Current	Surface Mount	Through Hole	VR (The same as system maximum input voltage)				
			20V	30V	40V	50V	60V
1A		√	1N5817	1N5818	1N5819		
		√	1N5820	1N5821	1N5822		
3A		√	MBR320	MBR330	MBR340	MBR350	MBR360
	√		SK32	SK33	SK34	SK35	SK36
	√			30WQ03	30WQ04	30WQ05	
		√		31DQ03	31DQ04	31DQ05	
		√	SR302	SR303	SR304	SR305	SR306
5A		√	1N5823	1N5824	1N5825		
		√	SR502	SR503	SR504	SR505	SR506
		√	SB520	SB530	SB540	SB550	SB560
	√			50WQ03	50WQ04	50WQ05	

FS1077

- **Typical Application**

For 24V ~ 12V/4A Version

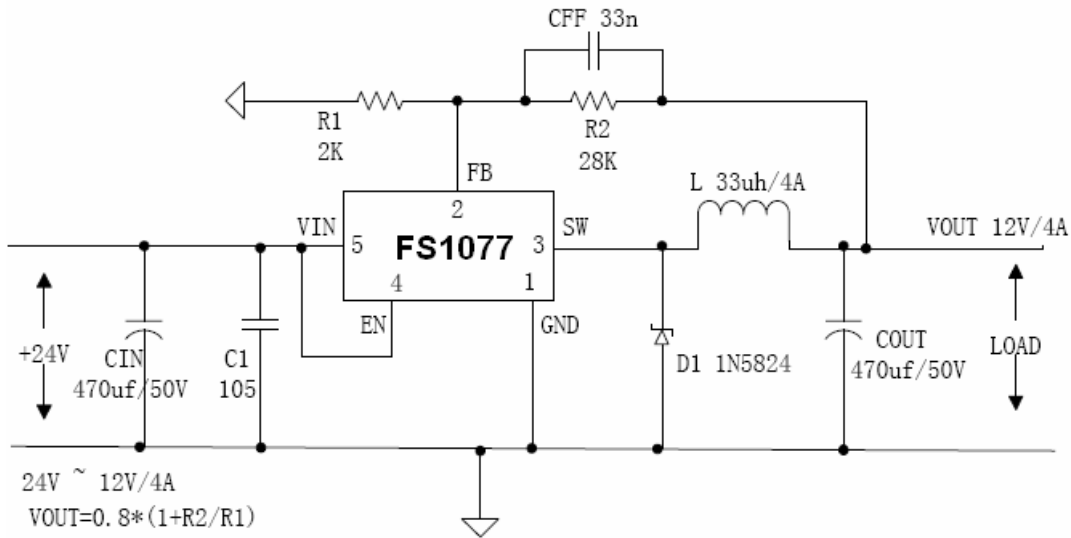

Figure. FS1077 System Parameters Test Circuit (24V ~ 12V/4A)

For 24V ~ 5V/5A

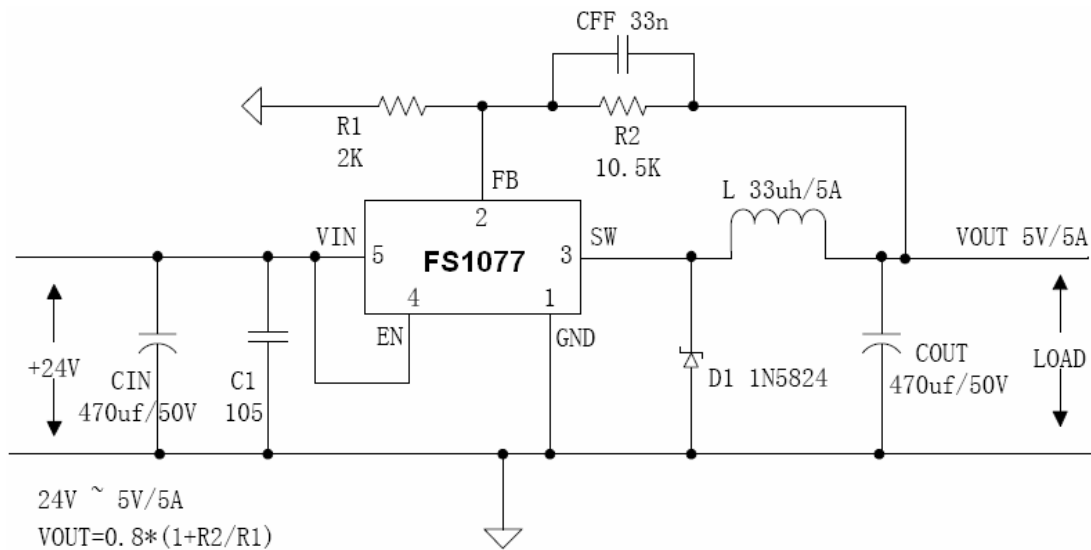
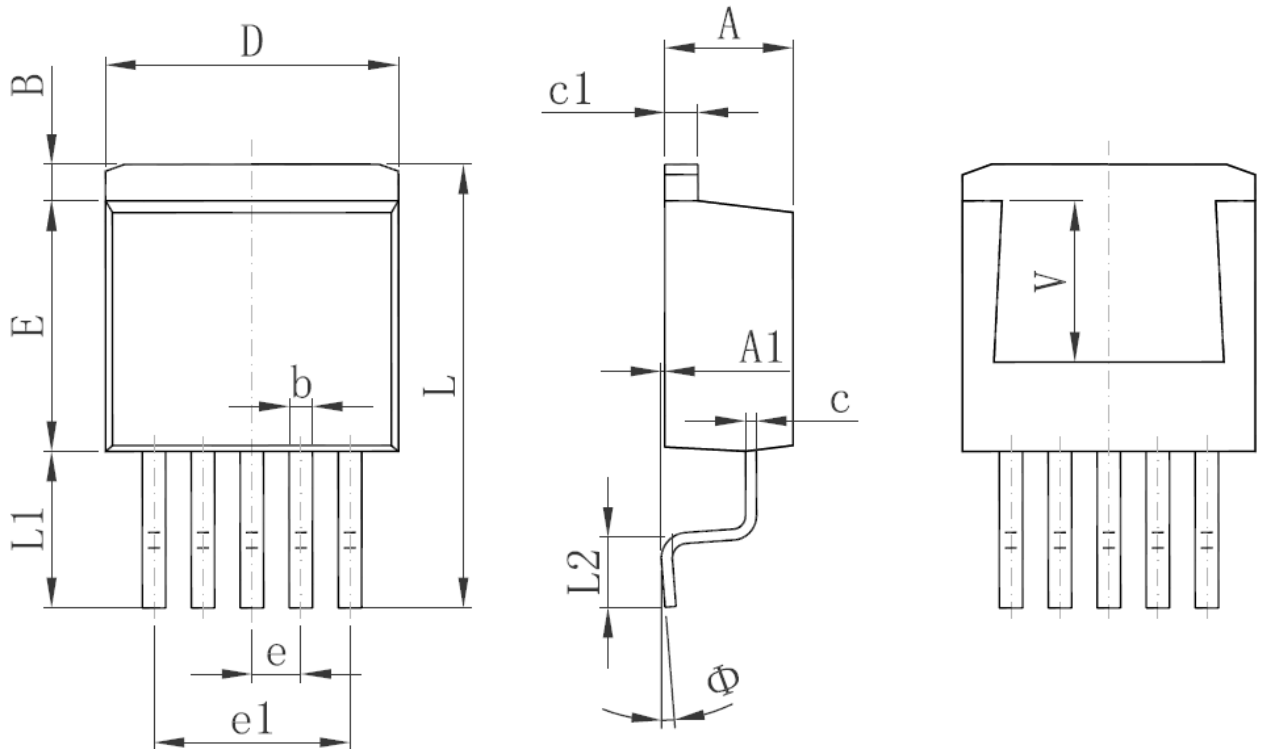

Figure. FS1077 System Parameters Test Circuit (24V ~ 5V/5A)

FS1077

Package Information

TO263-5L



Symbol	Dimensions In Millimeters		Dimensions In Inches	
	Min.	Max.	Min.	Max.
A	4.470	4.670	0.176	0.184
A1	0.000	0.150	0.000	0.006
B	1.560	1.760	0.061	0.069
b	0.710	0.910	0.028	0.036
c	0.310	0.530	0.012	0.021
c1	1.170	1.370	0.046	0.054
D	9.880	10.180	0.389	0.401
E	8.200	8.600	0.323	0.339
e	1.700 TYP.		0.067 TYP.	
e1	6.700	6.900	0.264	0.272
L	15.140	15.540	0.596	0.612
L1	5.080	5.480	0.200	0.216
L2	2.340	2.740	0.092	0.108
Φ	0°	8°	0°	8°
V	5.600 REF.		0.220 REF.	