

Simple Switcher 3A Step-Down Regulator

● Features

- 3.3V, 5V, 12V and adjustable output versions
- Adjustable version output range, 1.23V to 37V
- $\pm 4\%$ max over line and load conditions
- Available in TO220-5L and TO263-5L package
- Guaranteed 3A output current
- Wide input voltage range 6V to 40V

● Applications

- simple high-efficiency step-down regulator
- Efficient pre-regulator for linear regulators
- On-card switching regulators
- Positive to negative converter (Buck-boost)

● General Description

The FS1076 series of regulators are monolithic integrated circuits that provide all the active functions for a step-down (buck) switching regulator, capable of driving 3A load with excellent line and load regulation. These devices are available in fixed output voltages of 3.3V, 5V, 12V, and an adjustable output version

The FS1076 series requiring a minimum number of external components, these regulators are simple to use and include internal frequency compensation and a fixed-frequency oscillator.

The FS1076 series offers a high-efficiency replacement for Popular three-terminal linear regulators. It substantially reduces the size of the heat sink, and in some cases no heat sink is required. FS1076 series guaranteed $\pm 4\%$ tolerance on output voltage within specified input voltages and output load conditions. Also, the oscillator frequency accuracy is within $\pm 10\%$. External shutdown is included, featuring 70 μ A (typical) standby current. The output switch includes cycle-by-cycle current limiting, as well as thermal shutdown for full protection under fault conditions.

● Pin Configurations

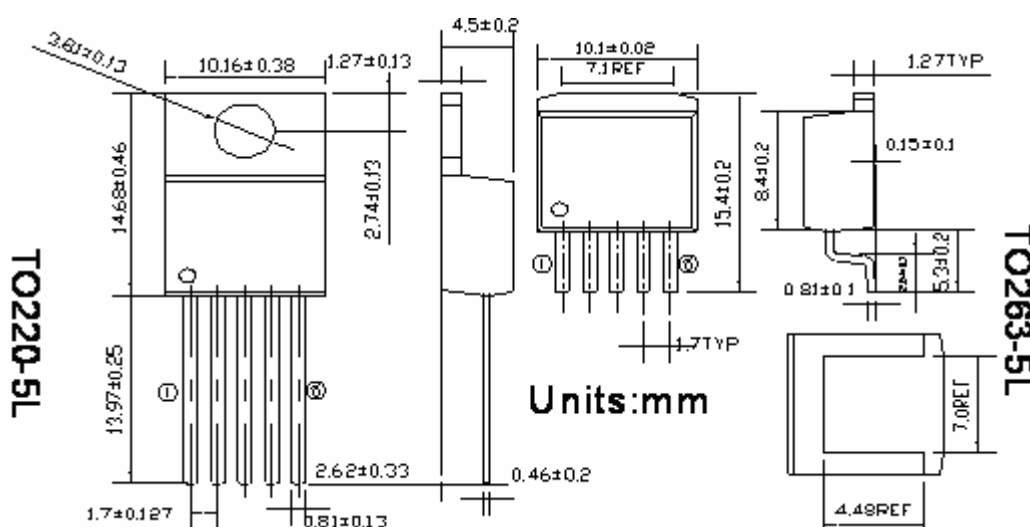

FS1076

- Pin Configuration

Pin name	TO220-5L	TO263-5L
①	Vin	Vin
②	Output	Output
③	GND	GND
④	Feedback	Feedback
⑤	$\overline{ON/OFF}$	$\overline{ON/OFF}$

- Typical Application

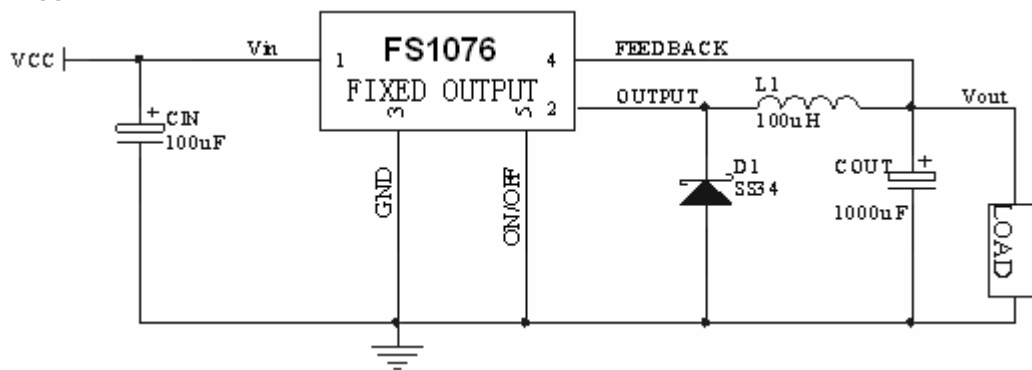

Fixed Output voltage Versions

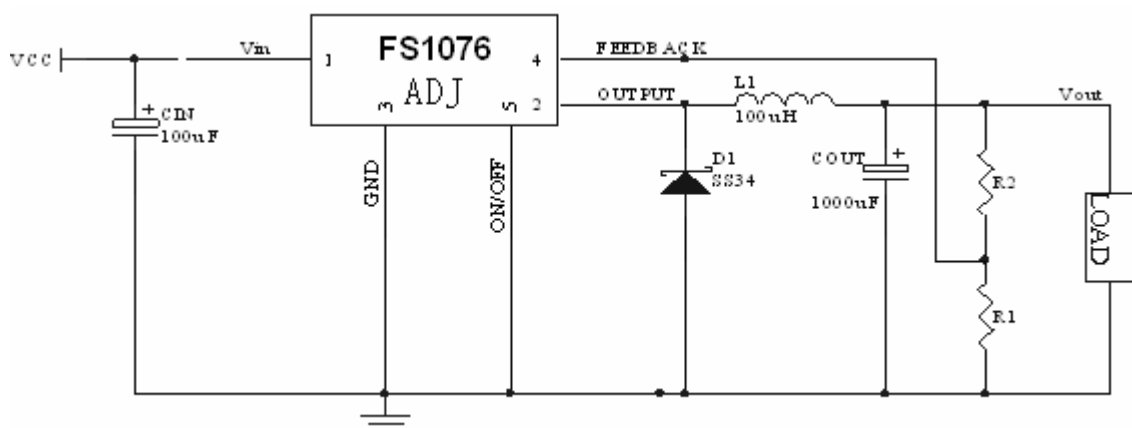

Adjustable Output Voltage Version

Circuit Figure 1

Application Note:

A) Input Capacitor (C_{IN})

A 100 uF aluminum electrolytic capacitor located near the input and ground pins provides sufficient bypassing

B). Catch Diode selection(D1)

For this example, a 3A current rating is adequate. Use a 20V IN5823 or SS34 Schottky diode for input voltage less than 20V, otherwise high rated voltage needed

C). Output Capacitor Selection(C_{OUT})

C_{OUT}=680uF to 2000uF standard aluminum electrolytic.

D). Inductor Selection (L1)

Inductor value required 100uH,

E). Adjustable Output Voltage Versions

Programming Output Voltage (Selecting R1 and R2,as shown in Figure 1)

$$V_{OUT} = V_{REF} \left(1 + \frac{R_2}{R_1}\right) \text{ Where } V_{REF} = 1.23V$$

R1 can be between 1k and 5k.(For best temperature coefficient and stability with time, use 1% metal film resistors)

$$R_2 = R_1 \left(\frac{V_{OUT}}{V_{REF}} - 1\right)$$

● **Absolute Maximum Ratings**

Parameter	Symbol	Ratings	Units
Maximum Supply Voltage	V _{IN}	45	V
$\overline{ON/OFF}$ Pin input voltage	V _{ON/OFF}	-0.3 ≤ V ≤ +V _{IN}	V
Minimum ESD Rating(C=100pF,R=1.5K Ω)	V _{ESD}	2	KV
Storage Temperature Range	T _{stg}	-65 ≤ T _{stg} ≤ +150	°C
Maximum Junction Temperature	T _{JT}	150	°C
Lead Temperature (Soldering) 10 seconds	T _{solder}	260	°C

FS1076

● Electrical Characteristics

T_J = 25°C, V_{IN} = 12V for the 3.3V, 5V, and Adjustable version, V_{IN} = 25V for the 12V version. I_{LOAD} = 500 mA,

Symbol	Parameter	Device	Test Conditions	Min	Typ	Max	Unit	
V _{in}	Operation voltage					40	V	
V _{out}	Output Voltage (Note1)	FS1076(3.3V)	V _{IN} =12V, I _{LOAD} =0.5A	circuit Figure 1	3.324	3.3	3.366	V
		FS1076(5.0V)			4.900	5.0	5.100	
		FS1076(12V)	V _{IN} =25V, I _{LOAD} =0.5A		11.76	12.0	12.24	
V _{out}	Output Voltage (Note1)	FS1076(3.3V)	6V ≤ V _{IN} ≤ 40V	0.5A ≤ I _{LOAD} ≤ 3A circuit Figure 1	3.168	3.3	3.432	V
		FS1076(5.0V)	8V ≤ V _{IN} ≤ 40V		4.800	5.0	5.225	
		FS1076(12V)	15V ≤ V _{IN} ≤ 40V		11.52	12.0	12.54	
V _{out}	Feedback Voltage (Note1)	FS1076(ADJ)	8V ≤ V _{IN} ≤ 40V V _{out} =5V		1.193	1.230	1.273	V
η	Efficiency	FS1076(3.3V)	V _{IN} =12V, I _{LOAD} =3A		--	75	--	%
		FS1076(5.0V)		--	77	--		
		FS1076(12V)	V _{IN} =15V, I _{LOAD} =3A		--	88	--	
		FS1076(ADJ)	V _{IN} =12V, I _{LOAD} =3A, V _{out} =5V		--	77	--	
I _b	Feedback Bias current		V _{out} =5.0, (Adjustable version only)		--	50	100	nA
f _o	Oscillator Frequency		(Note2)		47	50	58	KHz
V _{sat}	Saturation Voltage		I _{OUT} =3A (Note3)		--	1.4	1.8	V
DC	Max Duty Cycle		(Note4)		93	98	--	%
I _{CL}	Current Limit		(Notes 2,3)		4.2	5.8	6.9	A
I _L	Output Leakage Current		(Notes 5,6): Output=0V		--	--	2	mA
I _Q	Quiescent Current		(Note 5)		--	5	--	mA
I _{STBY}	Standby Quiescent Current		$\overline{\text{ON}}$ /OFF Pin=5V(OFF)		--	50	200	uA
V _{IH}	$\overline{\text{ON}}$ /OFF Pin Logic Input Level		V _{OUT} =0V		--	2.0	2.2	V
V _{IL}			V _{OUT} =Nominal Output Voltage		--	1.2		V
I _{IH}	$\overline{\text{ON}}$ /OFF Pin Logic Input Current		$\overline{\text{ON}}$ /OFF Pin=5V(OFF)		--	12	30	uA
I _{IL}	$\overline{\text{ON}}$ /OFF Pin Logic Input Current		$\overline{\text{ON}}$ /OFF Pin=0V (ON)		--	0	10	uA

Note 1: External components such as the catch diode, inductor, input and output capacitors can affect switching regulator system performance.

Note 2: The oscillator frequency reduces to approximately 11KHz in the event of fault conditions, such as output short or overload. And the regulated output voltage will drop approximately 40% from the nominal output voltage. This self-protection feature lowers the average power dissipation by lowering the minimum duty cycle from 5% down to approximately 2%.

Note 3: Output pin sourcing current. No diode, inductor or capacitor connected to output.

Note 4: Feedback pin removed from output and connected to 0V.

Note 5: Feedback pin removed from output and connected to +12V for the Adjustable, 3.3V, and 5V versions, and +25V for the 12V and 15V versions, to force the output transistor OFF.

Note 6: V_{IN} = 40V

FS1076

Typical Performance Characteristics

Normalized Output Voltage

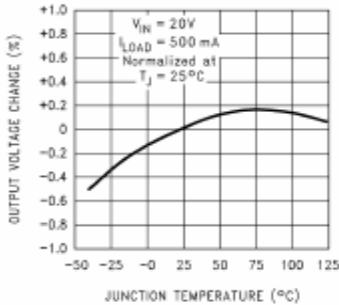

Line Regulation

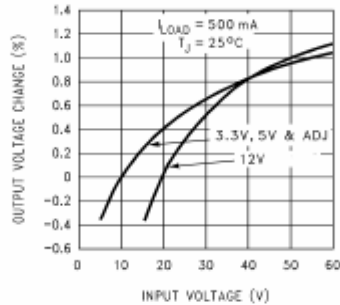

Dropout Voltage

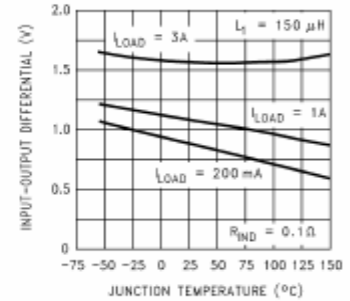

Minimum Operating Voltage

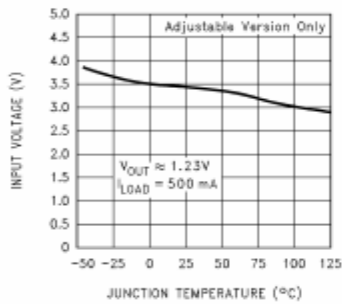

Quiescent Current vs Duty Cycle

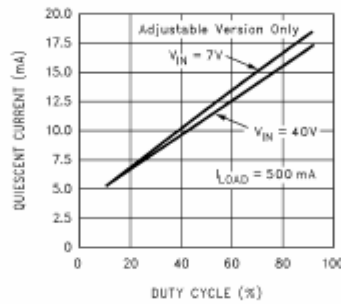

Feedback Voltage vs Duty Cycle

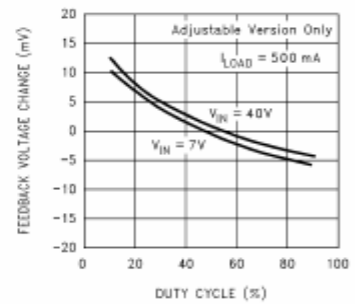

Current Limit

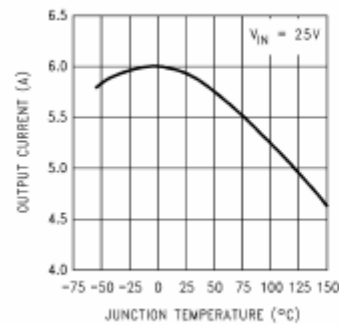

Quiescent Current

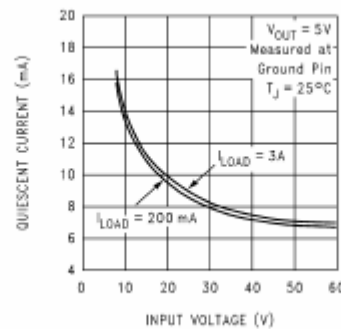

Standby Quiescent Current

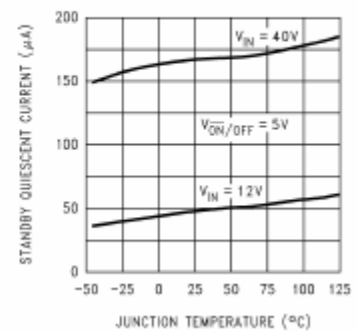

Oscillator Frequency

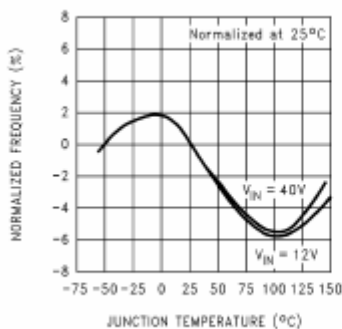

Switch Saturation Voltage

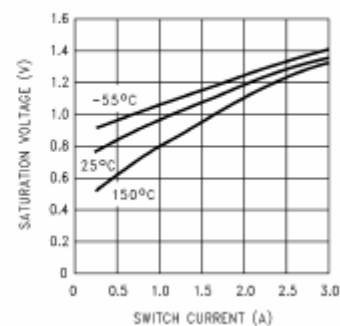

Feedback Pin Current

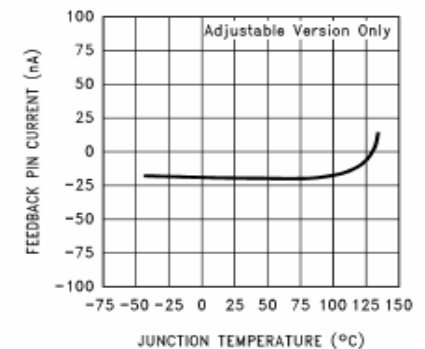

FS1076

Switching Waveforms

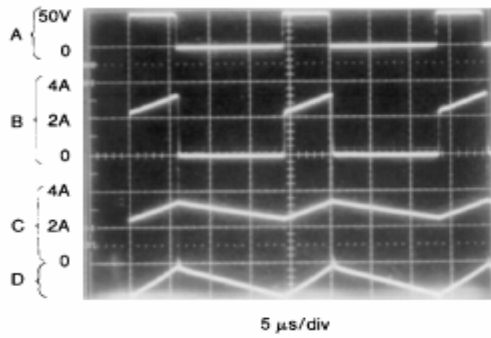

Load Transient Response

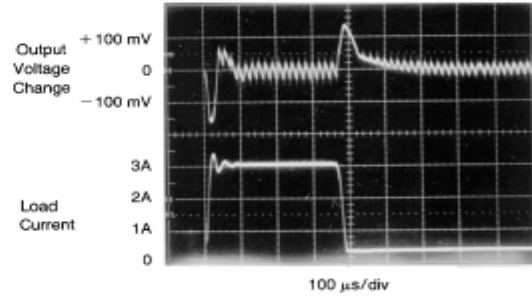

FS1076

- Package Information

TO220-5L

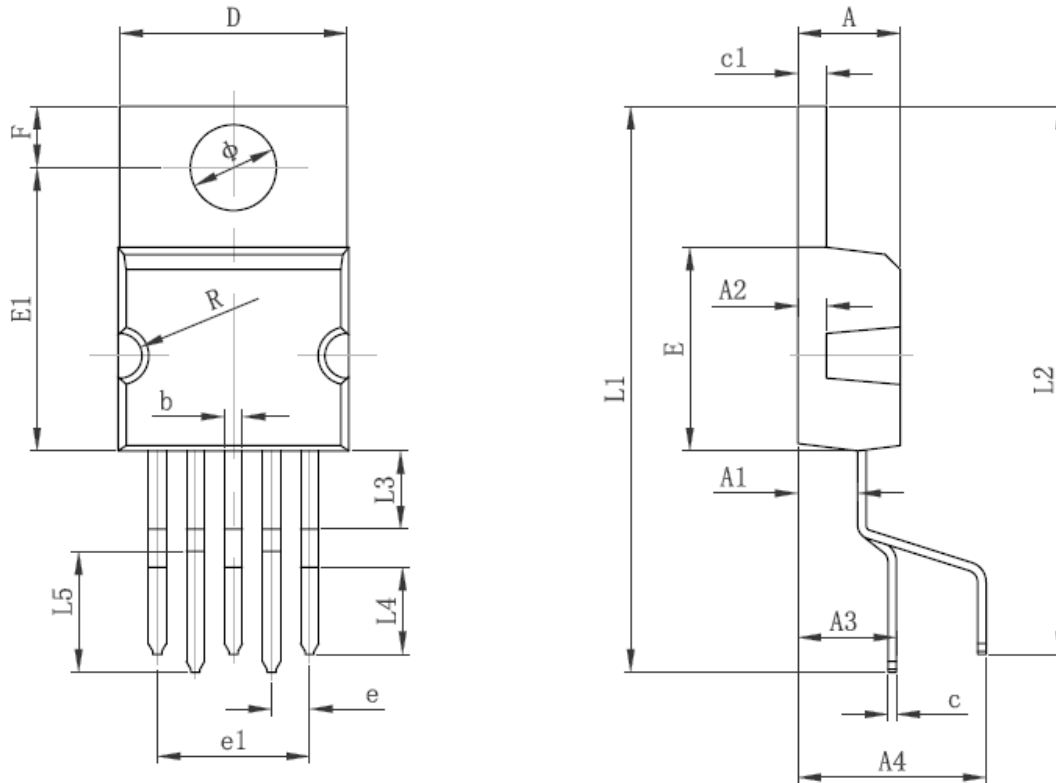

Symbol	Dimensions In Millimeters		Dimensions In Inches	
	Min	Max	Min	Max
A	4.470	4.670	0.176	0.184
A1	2.520	2.820	0.099	0.111
A2	1.170	1.370	0.046	0.054
A3	4.250	4.550	0.167	0.179
A4	8.250	8.550	0.325	0.337
b	0.710	0.910	0.028	0.036
c	0.310	0.530	0.012	0.021
c1	1.170	1.370	0.046	0.054
D	10.010	10.310	0.394	0.406
E	8.900	9.300	0.350	0.366
E1	12.460	12.860	0.491	0.506
e	1.700 TYP		0.220 TYP	
e1	6.700	6.900	0.264	0.272
e2	3.300	3.500	0.130	0.138
F	2.590	2.890	0.102	0.114
L1	25.100	25.500	0.988	1.004
L2	24.300	24.700	0.957	0.972
L3	3.400	3.600	0.134	0.142
L4	3.800	4.000	0.150	0.157
L5	5.300	5.500	0.209	0.217
R	0.950	1.050	0.037	0.041
Φ	3.790	3.890	0.149	0.153

TO263-5L

FS1076

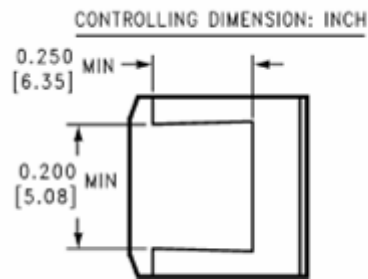
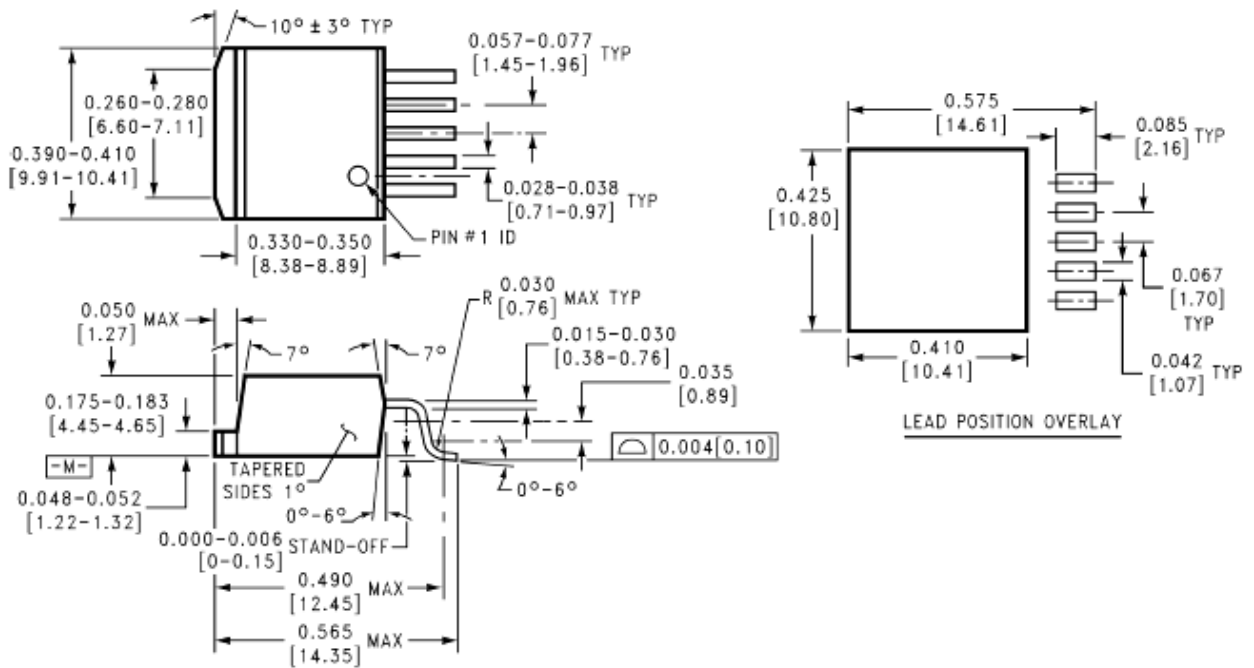

5-Lead TO-263