

24V, 1.5A, 1.4MHz Step-Down DC/DC Converter

● Features

- Wide 4.5V to 24V Input Voltage Range
- 1.5A Output Current (12VIN to 5VOUT)
- Output Adjustable Down to 0.81V
- 0.3Ω Internal Power MOSFET
- Up to 92% Efficiency
- Stable with Low ESR Ceramic Output Capacitors
- Fixed 1.4MHz Operating Frequency
- Internal Soft-Start Function
- Over Current Protection with Hiccup-Mode
- Thermal Shutdown
- Available in a SOT23-6 Package

● Applications

- TFT LCD Monitors
- Portable DVDs, Headphones, MP3 Players, etc.
- Car-Powered or Battery-Powered Equipment
- Set-Top Boxes
- Telecom Power Supplies
- DSL and Cable Modems and Routers

● Typical Application

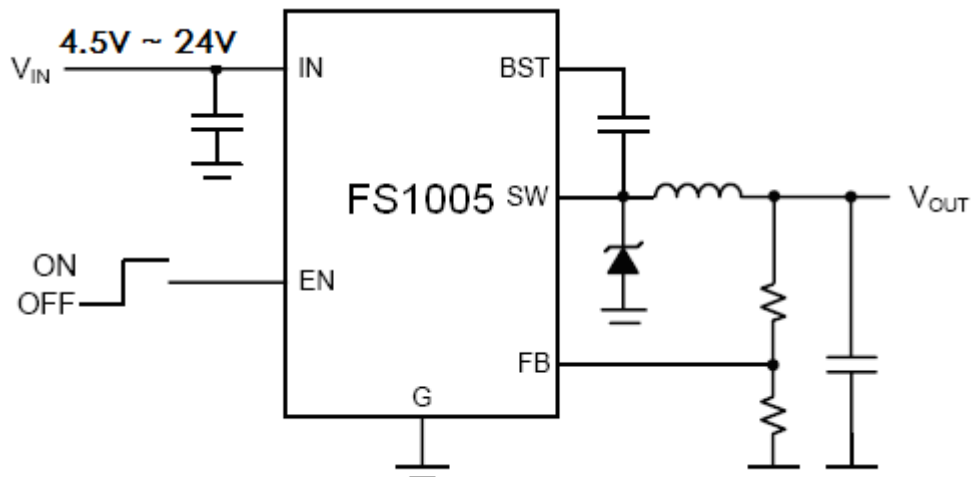

● General Description

The FS1005 is a current-mode step-down DC/DC converter that supplies up to 1.5A into 5V from a 12V input. 1.4MHz switching frequency allows the use of tiny external components, and internal loop compensation provides simple, stable power supplies with a minimum of external components. Optimized for use with ceramic input and output capacitors, the FS1005 provides a very compact 1.5A power supply for space constrained mobile and consumer applications.

The FS1005 operates over a wide input voltage range and utilizes current-mode operation to provide excellent line and load transient response while requiring no external compensation components. Fault protection includes cycle-by-cycle current limiting, frequency fold-back, hiccup mode, and thermal shutdown. Internal soft-start provides a controlled startup with no overshoot, even at light loads.

● Package Information

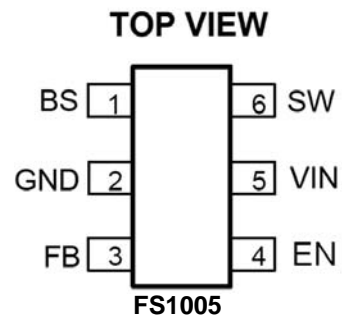

● Pin Descriptions

Pin Number	Pin Name	Pin Description
1	BST	Bootstrap. This pin acts as the power supply for the high-side switch's gate driver. Connect a 22nF capacitor between this pin and SW.
2	GND	Ground and Heat sink. Connect this pin to a large, uncovered PCB copper area for best heat dissipation.
3	FB	Feedback Input. The voltage at this pin is regulated to 0.81V. Connect to the center point of a resistive voltage-divider between OUT and G to set the output voltage.
4	EN	Enable Input. EN is pulled up to 5V with a 2 μ A current, and contains a precise 1.24V logic threshold. Drive this pin to a logic-high or leave unconnected to enable the IC. Drive to a logic-low to disable the IC and enter micro-power shutdown mode.
5	IN	Power supply input. Bypass this pin with a 10 μ F ceramic capacitor to G, placed as close to the IC as possible.
6	SW	Switch Output. Connect this pin to the switching end of the inductor.

● Functional Block Diagram

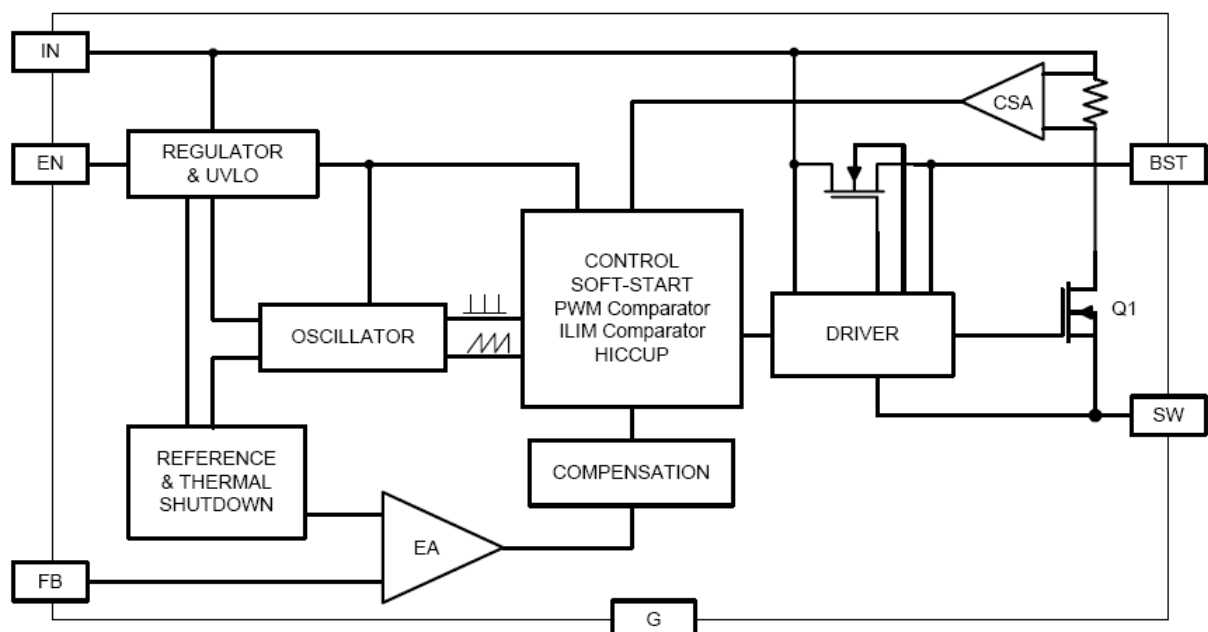

● **Absolute Maximum Ratings @ $T_A=25^\circ\text{C}$ unless otherwise noted**

PARAMETER	VALUE	UNIT
IN Supply Voltage	-0.3 to 28	V
SW Voltage	-1 to $V_{IN} + 1$	V
BST Voltage	$V_{SW} - 0.3$ to $V_{SW} + 7$	V
EN, FB Voltage	-0.3 to 6	V
Continuous SW Current	Internally Limited	A
Junction to Ambient Thermal Resistance (θ_{JA})	220	$^\circ\text{C}/\text{W}$
Maximum Power Dissipation	0.5	W
Operating Junction Temperature	-40 to 150	$^\circ\text{C}$
Storage Temperature	-55 to 150	$^\circ\text{C}$
Lead Temperature (Soldering, 10 sec)	300	$^\circ\text{C}$

● **Electrical Characteristics @ $T_A=25^\circ\text{C}$ unless otherwise noted**

PARAMETER	SYMBOL	TEST CONDITIONS	MIN	TYP	MAX	UNIT
Input Voltage	V_{IN}	$V_{OUT} = 3.3\text{V}$, $I_{LOAD} = 0\text{A}$ to 1.5A	4.5		24	V
Under Voltage Lockout Voltage	V_{UVLO}	Input Voltage Rising	4	4.2	4.49	V
Under Voltage Lockout Hysteresis				250		mV
Feedback Voltage	V_{FB}	$4.75\text{V} \leq V_{IN} \leq 20\text{V}$, $V_{COMP} = 1.5\text{V}$	0.79	0.81	0.83	V
Frequency Foldback Threshold				250		mV
High-side Switch On Resistance	R_{ONH}			0.300		Ω
Low-side Switch On Resistance	R_{ONL}			15		Ω
SW Leakage		$V_{EN} = 0$, $V_{SW} = 0\text{V}$		1	10	μA
Current Limit	I_{LTM}	$V_{IN} = 12\text{V}$, $V_{OUT} = 5\text{V}$, or $\text{EN} = \text{G}$, $\text{SW} = \text{G}$		1.8		A
Switching Frequency	f_{SW}		1.1	1.4	1.6	MHz
Foldback Switching Frequency		$V_{FB} = 0\text{V}$, or $\text{FB} = \text{G}$		467		kHz
Maximum Duty Cycle	D_{MAX}	$V_{FB} = 0.6\text{V}$		92		%
Minimum On-Time				75		ns
EN Threshold Voltage		EN Rising	1.12	1.24	1.36	V
EN Hysteresis		EN Rising		100		mV
EN Internal Pull-up Current				2		μA
Supply Current in Shutdown		$V_{EN} = 0\text{V}$ or $\text{EN} = \text{G}$		15	30	μA
Supply Current in Operation		$V_{EN} = 2\text{V}$, $V_{FB} = 1.0\text{V}$		1	2	mA
Thermal Shutdown Temperature				160		$^\circ\text{C}$
Thermal Shutdown Hysteresis				10		$^\circ\text{C}$

● Typical Performance Characteristics

($V_{IN} = 12V$, $L = 4.7\mu H$, $C1 = 10\mu F$, $C2 = 22\mu F$, $T_A = +25^\circ C$, unless otherwise specified.)

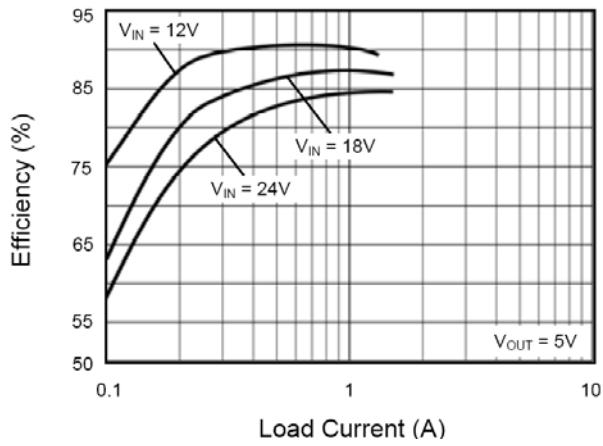

Efficiency vs. Load Current

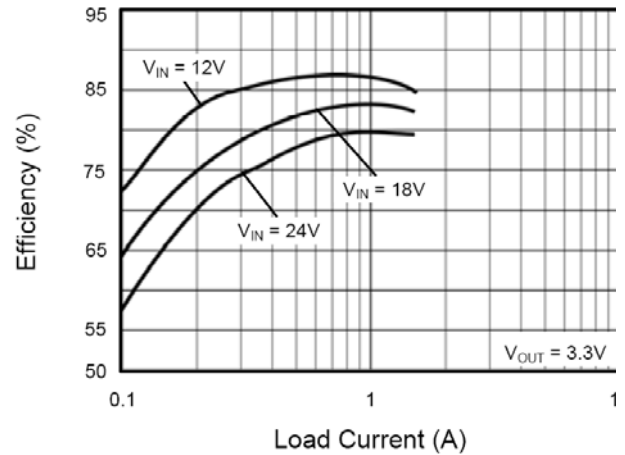

Efficiency vs. Load Current

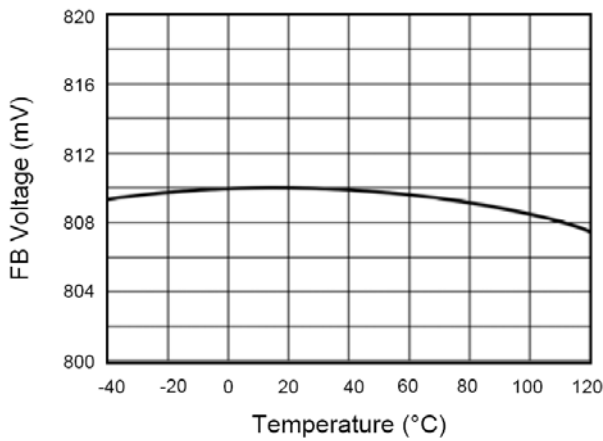

FB Voltage vs. Temperature

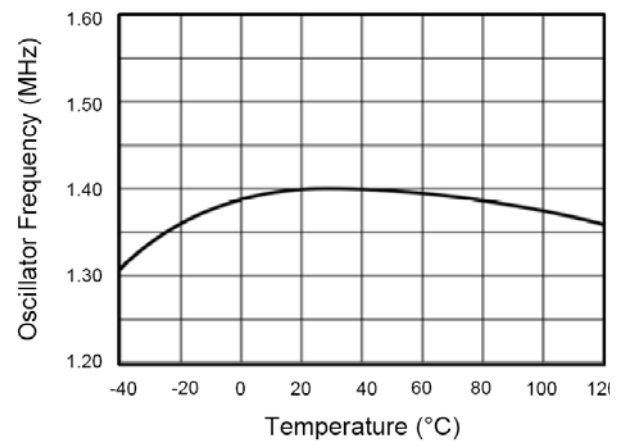

Oscillator Frequency vs. Temperature

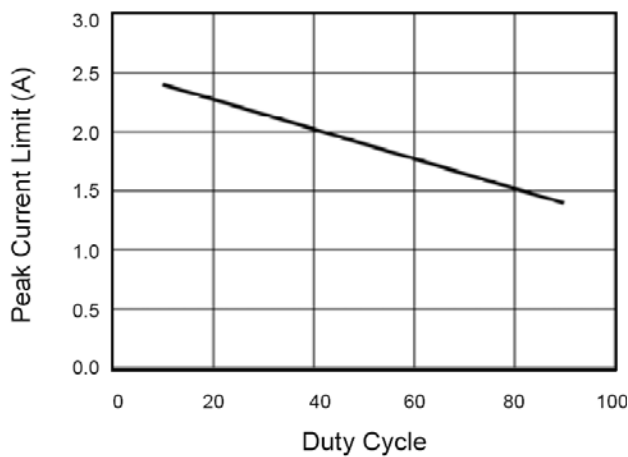

Peak Current Limit vs. Duty Cycle

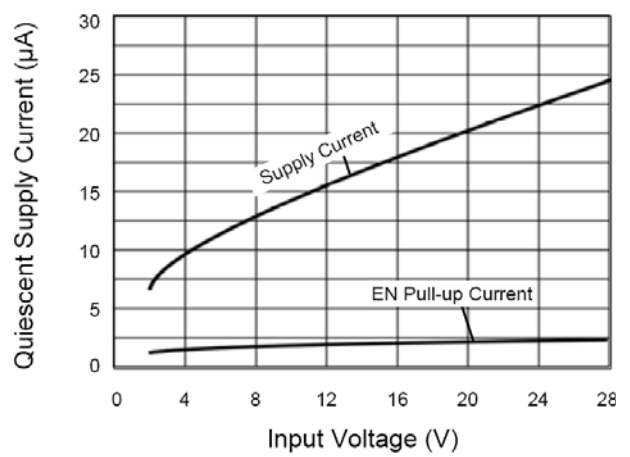

Shutdown Current vs. Input Voltage

FUNCTIONAL DESCRIPTION

The FS1005 is a current-mode step-down DC/DC converter that provides excellent transient response with no extra external compensation components. This device contains an internal, low-resistance, high-voltage power MOSFET, and operates at a high 1.4MHz operating frequency to ensure a compact, high-efficiency design with excellent AC and DC performance.

Setting the Output Voltage

An external voltage divider is used to set the output voltage, as well as provide a known impedance from VOUT to FB for compensation purposes. Connect a 50k Ω resistor from the output to FB to ensure stable compensation, and select the bottom resistor to provide the desired regulation voltage.

Selecting the Inductor

The FS1005 was optimized for use with a 4.7 μ H inductor. When choosing an inductor, choose one with a DC resistance of less than 250m Ω and a DC current rating that is typically 30% higher than the maximum load current. During typical operation, the inductor maintains a continuous current to output load. The inductor current has a ripple that is dependent on the inductance value. Higher inductance reduces the peak-to-peak ripple current. The trade off for high inductance value is the increase in inductor core size and series resistance, and a reduction in current handling capability. If efficiency at light loads (such as less than 100mA) is critical in the application, a larger inductor is recommended.

Rectifier Diode

Use a Schottky diode as the rectifier to conduct current when the High-Side Power Switch is off. The Schottky diode must have current rating higher than the maximum output current and the reverse voltage rating higher than the maximum input voltage.

Selecting the Input Capacitor

For best performance choose a ceramic type capacitor with X5R or X7R dielectrics due to their low ESR and small temperature coefficients. However, low ESR tantalum or electrolytic types may also be used, provided that the RMS ripple current rating is higher than 50% of the output current. For most applications, a 10 μ F capacitor is sufficient. The input capacitor should be placed close to the IN and G pins of the IC, with shortest possible traces. In the case of tantalum or electrolytic types, connect a small parallel 0.1 μ F ceramic capacitor right next to the IC.

Selecting the Output Capacitor

A 22 μ F ceramic capacitor with X5R or X7R dielectric provides the best results over a wide range of applications. The output capacitor also needs to have low ESR to keep low output voltage ripple. The output ripple voltage is: where IOUTMAX is the maximum output current, KRIPPLE is the ripple factor (typically 20% to 30%), RESR resistance is the ESR of the output capacitor, fSW is the switching frequency, L is the inductor value, and COUT is the output capacitance. In the case of ceramic output capacitors, RESR is very small and does not contribute to the ripple. In the case of tantalum or electrolytic type, the ripple is dominated by RESR multiplied by the ripple current. In that case, the output capacitor is chosen to have sufficiently low due to ESR, typically choose a capacitor with less than 50m Ω ESR.

External Bootstrap Diode

An external bootstrap diode (D2 in Figure 2) is recommended if the input voltage is less than 5.5V or if there is a 5V system rail available. This diode helps strengthen gate drive at lower input voltages, resulting in lower on-resistance and higher efficiency. Low cost diodes, such as 1N4148 or BAT54, are suitable for this application.

Shutdown Control

The FS1005 enable pin provides several features for adjusting and sequencing the power supply. An internal 2 μ A current source pull-up, and a precision 1.24V comparator with hysteresis. With these components, a user has the flexibility of using the EN pin as:

- 1) A digital on/off control by pulling down the EN current source with an external open-drain transistor. The voltage at EN is internally clamped to 6V.
- 2) A sequenced power supply by tying the EN pin through a resistor to the output of another power supply. The IC will be enabled when the voltage at EN exceeds 1.24V, or a resistor divider can be used to adjust the turn-on threshold.
- 3) An always-on converter by floating the EN pin or pulling EN to a desired voltage with a high value (1M Ω) external resistor. EN is internally clamped at 6V and will dissipate power if an external resistor attempts to pull EN above the 6V clamp voltage.
- 4) Line UVLO. If desired, to achieve a UVLO voltage that is higher than the internal UVLO, an external resistor divider from VIN to EN to GND can be used to disable the FS1005 until a higher input voltage is achieved. For example, it is not useful for a converter with 9V output

FS1005

to start up with a 4.2V input voltage, as the output cannot reach regulation. To enable the FS1005 when the input voltage reaches 12V, a 9kΩ/1kΩ resistor divider from IN to GND can be connected to the EN pin. Both the precision 1.2V threshold and 80mV hysteresis are multiplied by the resistor ratio, providing a proportional 6.67% hysteresis for any startup threshold. For the example of a 12V enable threshold, the turn off threshold would be 11.2V.

5) Power supply sequencing. By connecting a small capacitor from EN to GND, the 2μA current source and 1.24V threshold can provide a stable and predictable delay between startup of multiple power supplies. For example, a startup delay of roughly 10mS is provided using 150nF, and roughly 20mS by using 330nF. The EN current source is active anytime an input supply is applied, so disabling the IC or resetting the delay requires an external open-drain pull-down device to reset the capacitor and hold the EN pin low for shutdown.

FS1005 Typical 5V/1.5A Output Application

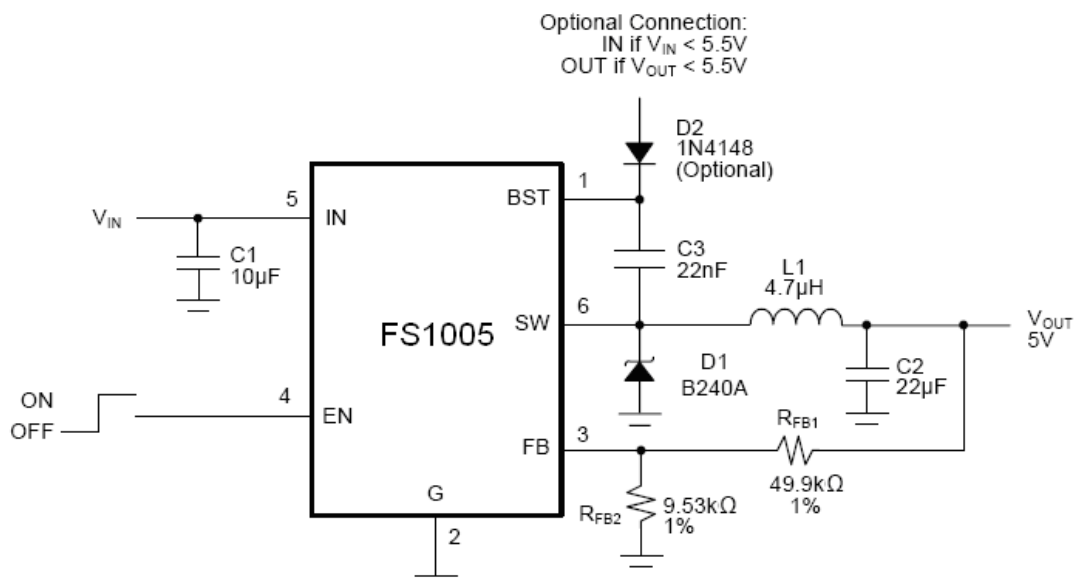

● SOT23-6 PACKAGE

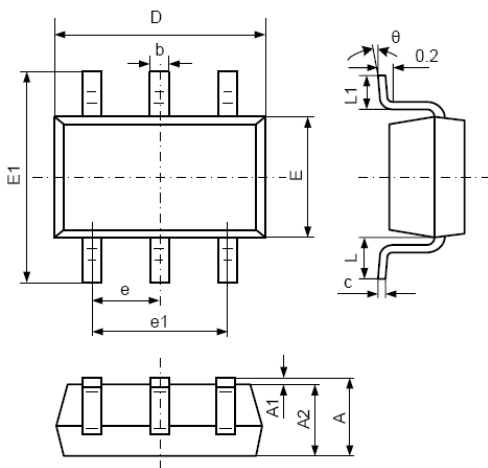

SYMBOL	DIMENSION IN MILLIMETERS		DIMENSION IN INCHES	
	MIN	MAX	MIN	MAX
A	1.050	1.250	0.041	0.049
A1	0.000	0.100	0.000	0.004
A2	1.050	1.150	0.041	0.045
b	0.300	0.500	0.012	0.020
c	0.100	0.200	0.004	0.008
D	2.820	3.020	0.111	0.119
E	1.500	1.700	0.059	0.067
E1	2.650	2.950	0.104	0.116
e	0.950 TYP		0.037 TYP	
e1	1.800	2.000	0.071	0.079
L	0.700 REF		0.028 REF	
L1	0.300	0.600	0.012	0.024
θ	0°	8°	0°	8°