

Synchronous Boost DC/DC Regulator

● Features

- High Efficiency: Up to 97%
- Low start-up voltage(load=1mA):0.8V
- The converter output voltage can be adjusted from 2.1V to 5.5V (in 0.1V step)
- Low Quiescent Current: 10 μ A
- Over-Current Protection
- Thermal Fault Protection
- SOT23-3/SOT89-3/TO92 package

● Applications

- Blue Tooth Headsets
- Portable Audio Players
- Wireless and DSL Modems
- Digital Cameras
- Power source for LED
- Power source for a single or dual-cell battery-powered equipments

● General Description

The FS1904 is PFM step-up DC-DC converter. The FS1904 can start up by supply voltage as low as 0.8V, and capable of delivering maximum 200mA output current at 3.3V output with 1.8V input voltage.

The FS1904 is available in a Pb-free, space-saving low profile 3-pin SOT23 ,TO92 or SOT89 package.

● Typical Application Circuit

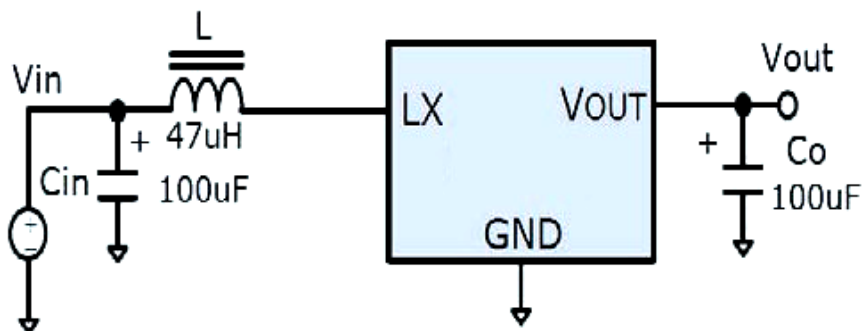

● Pin Configurations

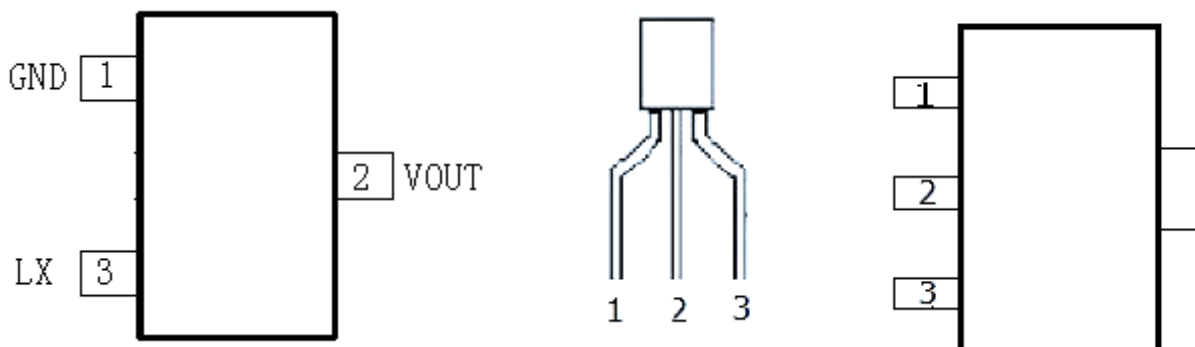

SOT23, TO92, SOT89: 1: GND 2: VOUT 3: LX

FS1904

● PIN DESCRIPTION

NAME	PIN	FUNCTION
GND	1	Ground pin
Vout	2	Power Output Pin. Tied to the source of the PMOS synchronous rectifier
LX	3	Power Switch Pin. Ties to the drains of the PMOS synchronous rectifier and the NMOS switch

● ORDER INFORMATION

No	P/N	FUNCTION	REMARKS
1	FS1904-XX	XX:Vout, SOT23-3	
2	FS1904-XXS	XX:Vout, S:SOT89-3	
3	FS1904-XXT	XX:Vout, T:TO92-3	

● ABSOLUTE MAXIMUM RATINGS (Note 1)

Input Supply Voltage -0.3V to 6.5V Operating Temperature Range ... -40°C to +85°C

Lead Temperature(Soldering, 10s)+300°C

LX Voltage-0.3V to (Vin+0.3V) Storage Temperature Range-65°C to 150°C

● Electrical Characteristics

(VOUT=3.3V, TA = 25°C, unless otherwise noted.)

Parameter	Conditions	MIN	TYP	MAX	unit
Input Voltage Range	Minimum start-up voltage, Iload=1mA			0.9	V
Minimum Operating Voltage				0.6	V
Quiescent Current	V=1.05%*Vout		12	18	μA
Output voltage accuracy		-3		3	%
Maximum on timer			2		μS
Minimum off timer			0.25		μS
On Resistance of PMOS	ILX=100mA		300		mΩ
On Resistance of NMOS	ILX=-100mA		200		mΩ
Peak Current Limit	VIN= 3V, Vout=90%		1		A

Note 1: Absolute Maximum Ratings are those values beyond which the life of a device may be impaired.

Note 2: TJ is calculated from the ambient temperature TA and power dissipation PD according to the following formula: $T_J = T_A + (PD) \times (250^\circ\text{C/W})$.

Note3: 100% production test at +25°C. Specifications over the temperature range are guaranteed by design and characterization.

Note 4: Dynamic supply current is higher due to the gate charge being delivered at the switching frequency.

- **Typical Performance Characteristics**

Cin=Cout=100uF, L=47uH, Vout=2.7V

I_o VS Startup Voltage

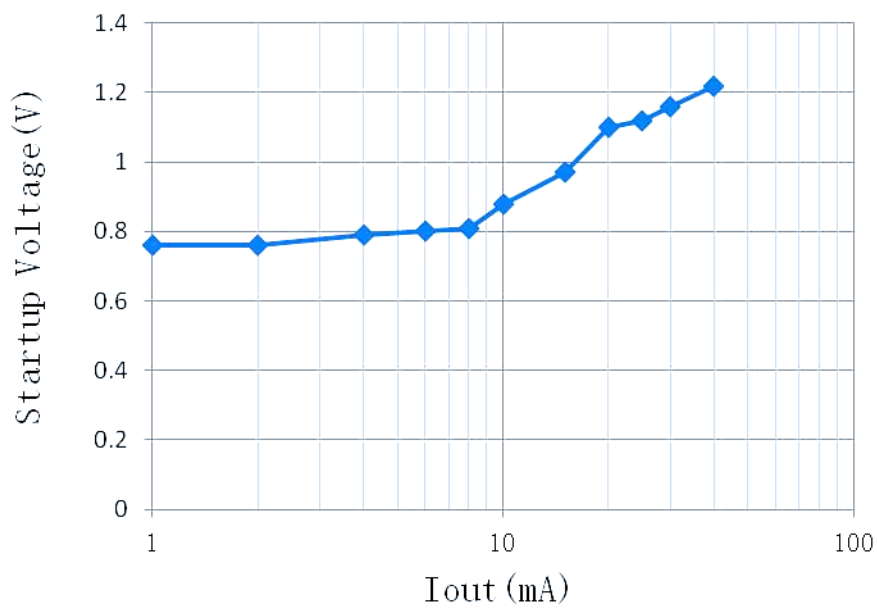

I_o VS Startup Voltage

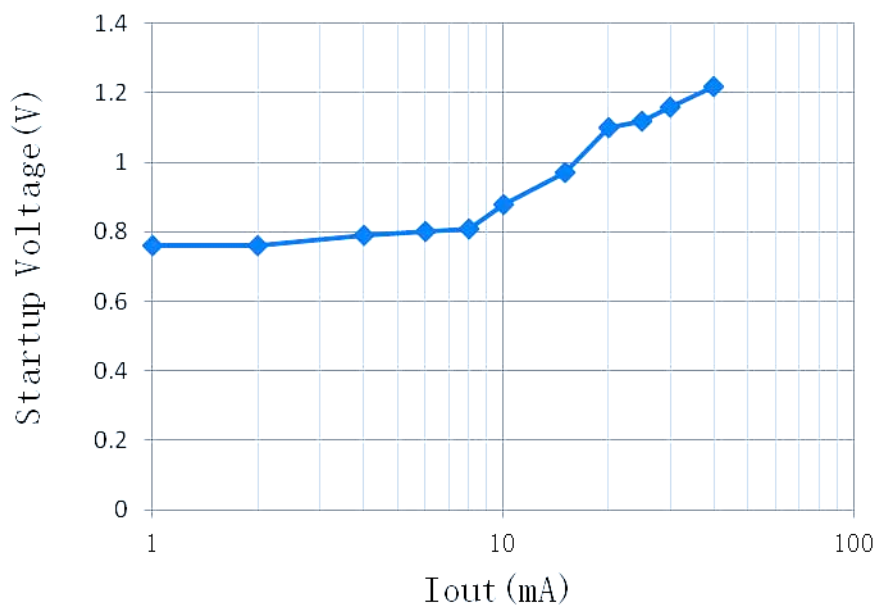

Iout VS Efficiency

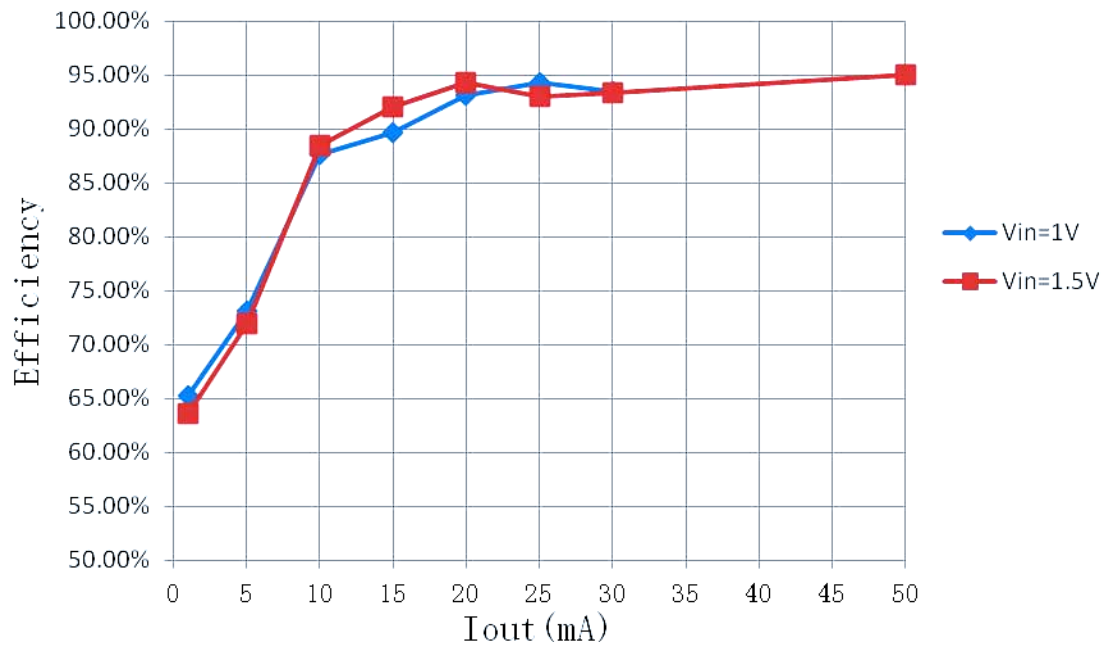

Ripple(Vin=1.5V, Vout=2.7V, Io=20mA, Cin=Cout=100uF, L=47uH)

