

1MHz, 1A output current, Synchronous Boost Converter

- **Features**

- Wide input range: 2.6-5V input, 1 A @5V Vout
- 1MHz switching frequency
- Low $R_{DS(ON)}$: 110m Ω @5V NMOS and 50m Ω @5V PMOS
- Up to 93% efficiency
- Accurate Reference: 0.6VREF
- Under-Voltage lockout Protection
- Over-Temperature Protection
- Short Protection
- Internal Soft Start
- 1uA Shutdown current
- RoHS Compliant and Halogen Free
- Compact package: ESOP8

- **Application**

- iPad- like tablet computers
- Smart phones ● Other portable devices

- **General Description**

The FS1902 is a compact, high-efficiency, synchronous step-up converter with power MOSFETs integrated for a single-cell Li-ion/polymer battery. This converter consumes only 100uA quiescent current when no switching. When current load is light, this converter enters burst mode to obtain high efficiency. When current load is heavy enough, it enters fixed-frequency PWM mode. It adopts peak current mode for fast transient response with internal compensation. This converter contains cycle-by-cycle current limiting and short protection circuit. It is suitable for iPad-like computers, smart phones and portable handheld devices. The device is packed in ESOP8 package.

- **Typical Application Circuit**

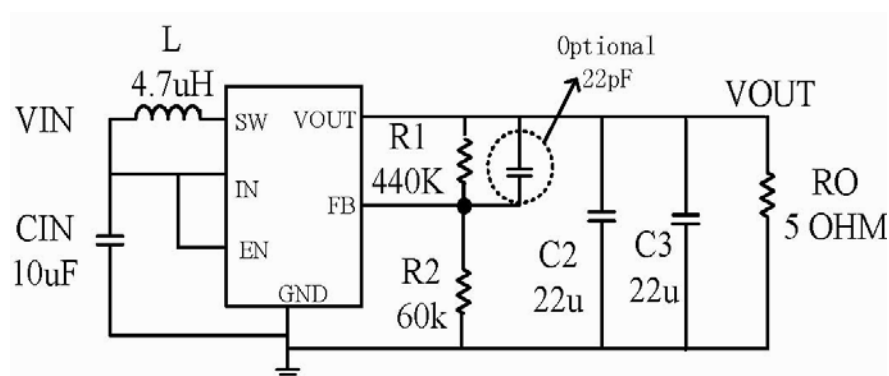

● 引脚排列

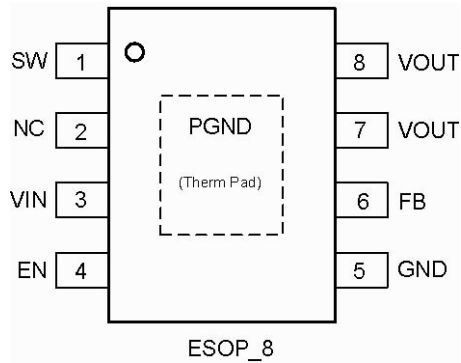

Pin NO.	Pin Name	Pin Function
1	SW	Switching Terminal
2	NC	No Connection
3	VIN	Input Supply Pin. Must be locally bypassed.
4	EN	Enable pin. A high input at EN enables the device.
5	GND	Analog Ground
6	FB	Feedback pin.
7	VOUT	The Output of The Chip
8	VOUT	The Output of The Chip
9	PGND	Thermal Pad

● Block Diagram

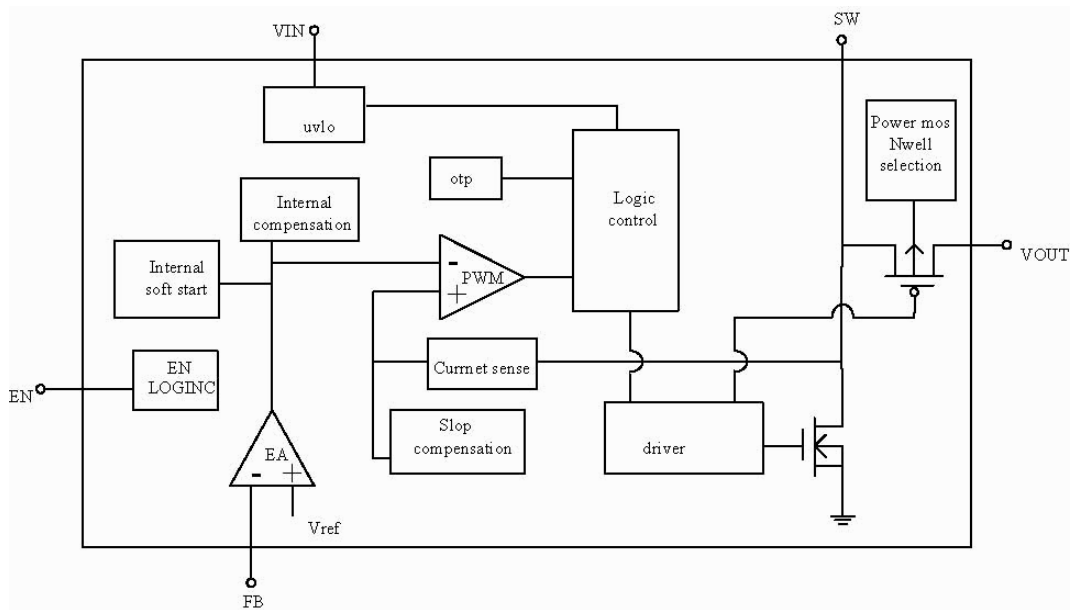

● Absolute Maximum Ratings (Note 1)

SYMBOL	NAME	VALUE	UNIT
VIN	Input Voltage	-0.3~5.5	V
VSW	Voltage at SW Pin	-0.5~5.5	V
VIO	All Other I/O Pins	GND-0.3 to VDD+0.3	V
P _{TR1}	Thermal Resistance, ESOP8		°C/W
	Θ _{JA}	50	
T _{stg}	Storage Temperature	-55 to 150	°C
T _{solder}	Package Lead Soldering Temperature	260°C, 10s	
MSL Level		1	
ESD Susceptibility	HBM(Human Body Mode)	2	kV

Note1: Exceeding these ratings may damage the device.

● **Recommended Operating Conditions**(Note 2)

SYMBOL	NAME	VALUE	UNIT
VIN	VIN Supply Voltage	2.5 to 5.5	V
VSW	Output Voltage	VIN to 5.5	V
TOTP	Operating Temperature	-40 to +85	°C

Note2: The device is not guaranteed to function outside of its operating rating.

● **Electrical Characteristics** ($V_{IN}=V_{EN}=3V$, $T_{opt}=25^{\circ}C$ unless specified otherwise.)

SYMBOL	ITEMS	CONDITIONS	Min.	Typ.	Max.	UNIT
VIN	Input Voltage		2.5		4.5	V
Feedback						
VFB	Feedback Voltage		588	600	612	mV
Ibias	FB Pin Input Bias Current			0.05	1	μA
UVLO						
UVLO	Under Voltage Lock Out	Rising		2.8		V
V _{UVLO_HYS}				0.3		V
Operating Current						
I _{off}	Shutdown Current	V _{EN} =0V		0.1	1	μA
I _{sb}	No Switch	V _{in} =3V VFB=0.65V		100		μA
F _{sw}	Switching Frequency			1		MHz
D _{max}	Maximum Duty Cycle	VFB=0V		90		%
Chip Enable						
V _{EN_H}	EN Minimum High Level		1.5			V
V _{EN_L}	EN Maximum Low Level				0.4	V
V _{HYS}	EN Hysteresis			90		mV
	EN Input Bias Current	V _{SW-ON} =0V, 5V			1	μA
OTP						
OTP				140		oc
OTP Hysteresis				20		oC
Output Switch						
R _{ON(NMOS)}	SW On Resistance (Note 3)			0.11		Ω
R _{ON(PMOS)}				0.15		Ω
I _{LIMIT}	SW Current Limit	V _{out} =4.5		3.3		A
I _{LEAK}	SW Leakage Current	V _{sw} =5V		0.01	1	μA
Soft Start						
t _{ss}	Soft Start Time (Note 3)	VIN Power On		400		μS

Note3: Guaranteed by design.

- **Typical Performance Characteristics**

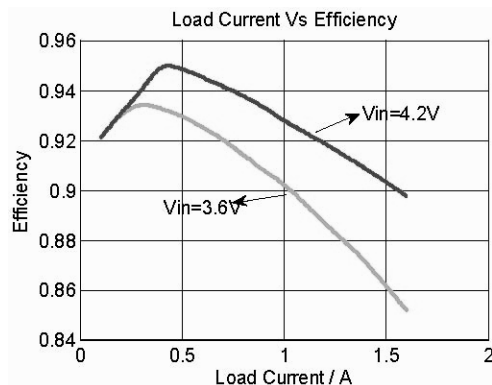

Figure 1. Efficiency Curve

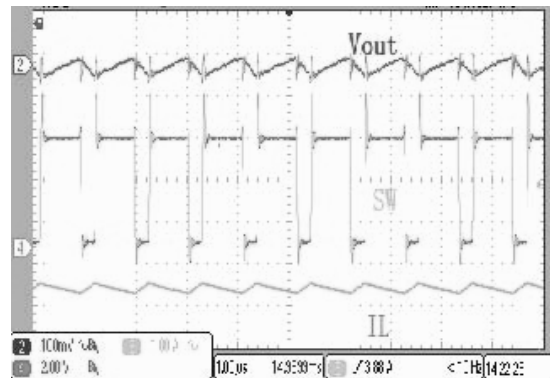

Figure 2. Steady-state Waveform

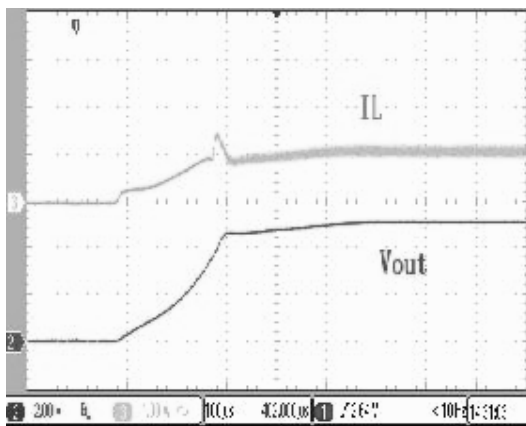

Figure 3. Startup Waveform

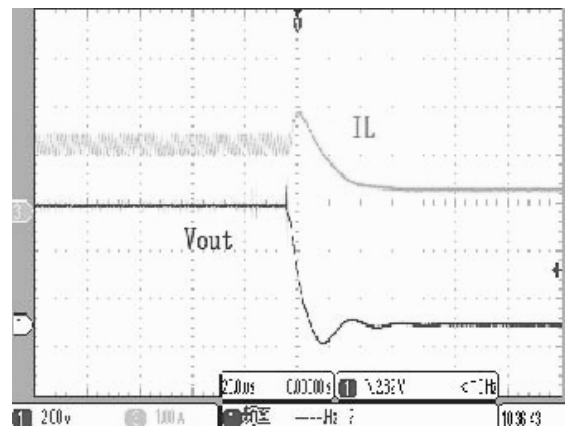

Figure 4. Short Waveform

- **Operation Description**

- **Controller Circuit**

The FS1902 current-mode step-up DC-DC switching converter uses a fixed-frequency PWM architecture with output short-protection function. The FS1902 step-up DC-DC switching converter typically generates a 5V output voltage from a single-cell battery input voltage. In light-load mode, the converter switches when needed, consumes only 130 μ A of quiescent current. In heavy-load mode, the converter switches every cycle at a constant frequency as fixed-PWM. The FS1902 is highly efficient, with internal and synchronous switches. Shutdown function reduces the quiescent current to less than 0.1 μ A. Low quiescent current and high efficiency make this device ideal for portable equipment. The FS1902 is optimized for use in iPad-like computers, smart phones, portable handheld devices and other applications requiring low quiescent current for maximum battery life.

- **Synchronous Rectifier**

A special circuit is applied to disconnect the load from the input during shutdown of the converter. In conventional synchronous rectifier circuits, the back-gate diode of the high-side PMOS is forward biased in shutdown and allows current flowing from the battery to the output. This device however uses a special circuit which takes the cathode of the back-gate diode of the high-side PMOS and disconnects it from the

source when the regulator is not enabled (EN = low). The benefit of this feature for the system design engineer is that the battery is not depleted during shutdown of the converter. No additional components have to be added to the design to make sure that the battery is disconnected from the output of the converter.

Under Voltage Lockout

An under voltage lockout function prevents device start-up if the supply voltage on VBAT is lower than approximately 2.8V. When in operation and the battery is being discharged, the device automatically enters the shutdown mode if the voltage on VBAT drops below approximately 2.5V. This under voltage lockout function is implemented in order to prevent the malfunctioning of the converter.

Soft Start

When the device enables the internal start-up cycle, it starts with the first step, the precharge phase. During precharge, the rectifying switch is turned on until the output capacitor is charged to a value close to the input voltage. The rectifying switch current is limited in that phase. This also limits the output current under short-circuit conditions at the output. After charging the output capacitor to the input voltage the device starts switching.

● Application Information

Because of the high integration in the FS1902, the application circuit based on this regulator IC is rather simple. Only input capacitor CIN, output capacitor COUT, inductor L and feedback resistors (R1 and R2) need to be selected for the targeted applications specifications.

Feedback resistor dividers R1 and R2:

Choose R1 and R2 to program the proper output voltage. To minimize the power consumption under light loads, it is desirable to choose large resistance values for both R1 and R2. A value of between 10k and 1M is recommended for both resistors. If R1=200k is chosen, then R2 can be calculated to be:

$$R2 = (R1 \times 0.6V) / (VOUT - 0.6V)$$

Input capacitor CIN:

To minimize the potential noise problem, place a typical X5R or better grade ceramic capacitor really close to the IN and GND pins. Care should be taken to minimize the loop area formed by CIN, and IN/GND pins. In this case a 10uF low ESR ceramic is recommended.

Output capacitor COUT:

The output capacitor is selected to handle the output ripple noise requirements. Both steady state ripple and transient requirements must be taken into consideration when selecting this capacitor. For the best performance, it is recommended to use X5R or better grade ceramic capacitor with 10V rating and more than two pcs 22uF Capacitor.

Boost inductor L:

The recommended values of inductor are 2.2 to 4.7 μ H. Small size and better efficiency are the major concerns for portable device, such as FS1902 used for mobile phone. The inductor should have low core loss at 1MHz and low DCR for Better efficiency. To avoid inductor saturation current rating should be considered.

Start-up and Inrush Current:

The FS1902 has internal soft start to limit the amount of current through VIN at startup and also limit the amount of overshoot on the output. The soft start is realized by gradually increasing the current limit during start-up.

● Package Information

ESOP8

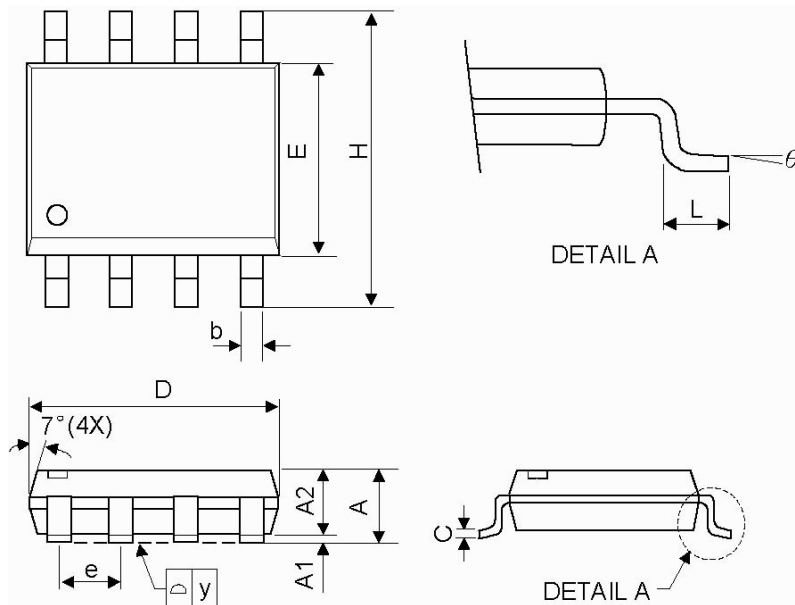

SYMBOL	MILLIMETER			INCHES		
	MIN	NOM	MAX	MIN	NOM	MAX
A	-	-	1.75	-	-	0.069
A1	0.1	-	0.25	0.04	-	0.1
A2	1.25	-	-	0.049	-	-
C	0.1	0.2	0.25	0.0075	0.008	0.01
D	4.7	4.9	5.1	0.185	0.193	0.2
E	3.7	3.9	4.1	0.146	0.154	0.161
H	5.8	6	6.2	0.228	0.236	0.244
L	0.4	-	1.27	0.015	-	0.05
b	0.31	0.41	0.51	0.012	0.016	0.02
e	1.27 BSC			0.050 BSC		
y	-	-	0.1	-	-	0.004
θ	0°	-	8°	0°	-	8°