

High Efficiency 1.2MHz 2A Step Up Regulator

● Features

- Integrated 100mΩ Power MOSFET
- 2V to 24V Input Voltage
- 1.2MHz Fixed Switching Frequency
- Internal 4A Switch Current Limit
- Adjustable Output Voltage
- Internal Compensation
- Up to 28V Output Voltage
- Automatic Pulse Frequency Modulation
- Mode at Light Loads
- up to 97% Efficiency
- Available in a 6-Pin SOT23-6 Package

● Applications

- Battery-Powered Equipment
- Set-Top Boxed
- White LED Driver
- DSL and Cable Modems and Routers
- Networking cards powered from PCI or PCI express slots

● General Description

The FS1503 is a constant frequency, 6-pin SOT23 current mode step-up converter intended for small, low power applications. The FS1503 switches at 1.2MHz and allows the use of tiny, low cost capacitors and inductors 2mm or less in height. Internal soft-start results in small inrush current and extends battery life.

The FS1503 features automatic shifting to pulse frequency modulation mode at light loads. The FS1503 includes under-voltage lockout, current limiting, and thermal overload protection to prevent damage in the event of an output overload. The FS1503 is available in a small 6-pin SOT-23 package.

● Pin Configurations (SOT23-6L)

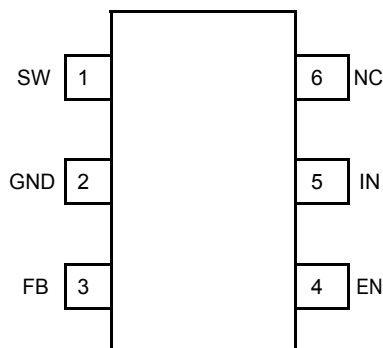

PIN DESCRIPTION

PIN	NAME	FUNCTION
1	SW	Power Switch Output. SW is the drain of the internal MOSFET switch. Connect the power inductor and output rectifier to SW. SW can swing between GND and 28V.
2	GND	Ground Pin
3	FB	Feedback Input. The FB voltage is 0.6V. Connect a resistor divider to FB.
4	EN	Regulator On/Off Control Input. A high input at EN turns on the converter, and a low input turns it off. When not used, connect EN to the input supply for automatic startup.
5	IN	Input Supply Pin. Must be locally bypassed
6	NC	NC

TYPICAL APPLICATION

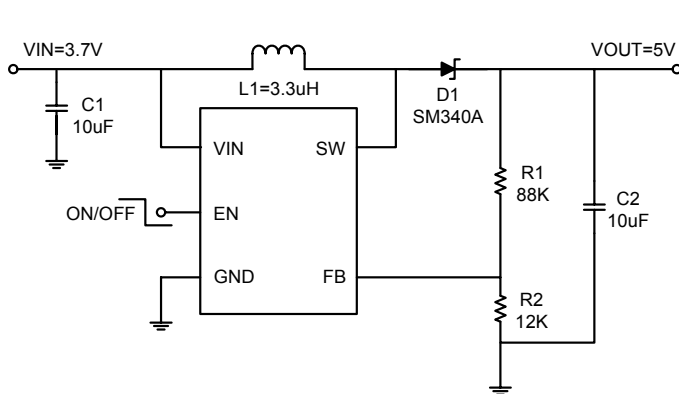

Figure 1: Basic Application Circuit

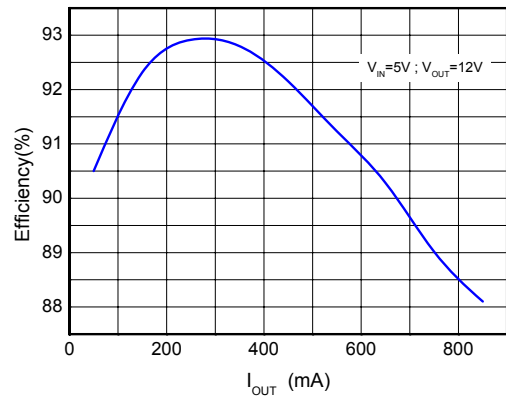

Figure 2: Efficiency Curve

ABSOLUTE MAXIMUM RATINGS

IN, EN voltages	-0.3V to 26V
Operating Temperature.....	-40°C to +85°C
FB Voltages.....	-0.3V to 6V
Junction Temperature	160°C
SW Voltage	-0.3V to 30V
Storage Temperature Range.....	-65°C to 150°C
Peak SW Sink and Source Current	4A
Lead Temperature (Soldering, 10s) ...	+300°C

● ELECTRICAL CHARACTERISTICS

($V_{IN}=V_{EN}=5V$, $T_A = 25^\circ C$, unless otherwise noted.)

Parameter	Conditions	MIN	TYP	MAX	unit
Operating Input Voltage		2		24	V
Under Voltage Lockout				1.98	V
Under Voltage Lockout Hysteresis			100		mV
Current (Shutdown)	$V_{EN}= 0V$		0.1	1	μA
Quiescent Current (PFM)	$V_{FB}=0.7V$ No switch		100	200	μA
Quiescent Current (PWM)	$V_{FB}=0.5V$ switch		1.6	2.2	mA
Switching Frequency			1.2		MHz
Maximum Duty Cycle	$V_{FB} = 0V$	90			%
EN Input High Voltage		1.5			V
EN Input Low Voltage				0.4	V
FB Voltage		0.588	0.6	0.612	V
FB Input Bias Current	$V_{FB} = 0.6V$	-50	-10		nA
SW On Resistance (1)			80	150	m Ω
SW Current Limit (1)	$V_{IN}= 5V$, Duty cycle=50%		4		A
SW Leakage	$V_{SW} = 20V$			1	μA
Thermal Shutdown			155		$^\circ C$

Note:

1) Guaranteed by design, not tested.

● Typical Block Diagram

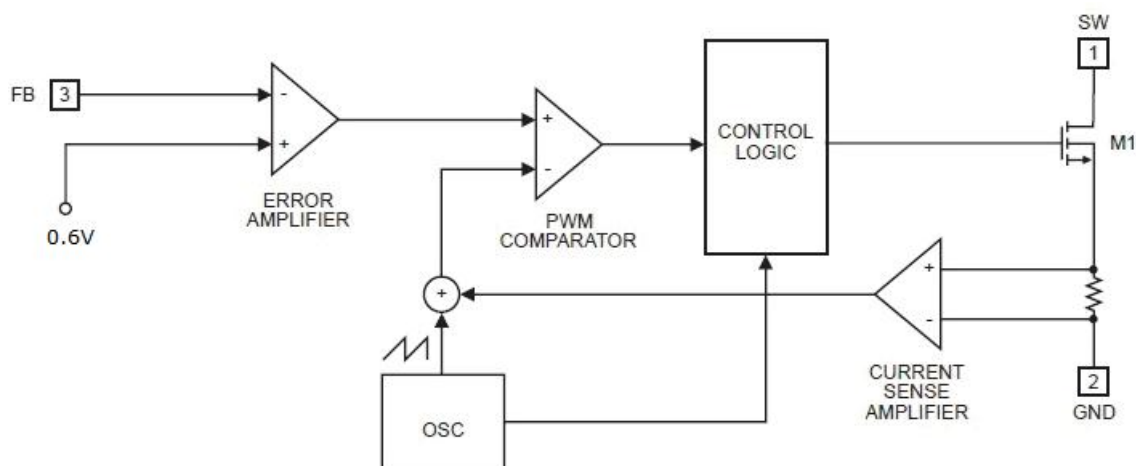
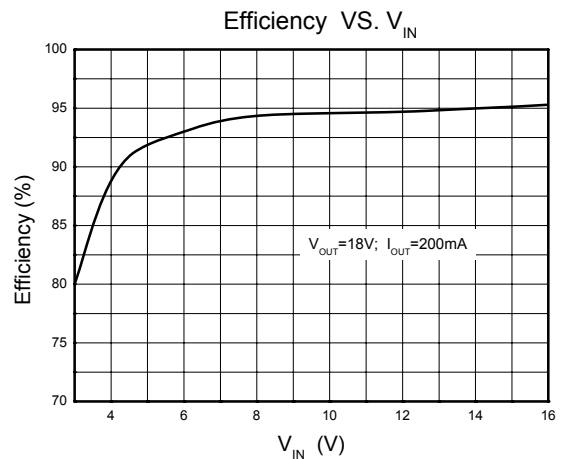
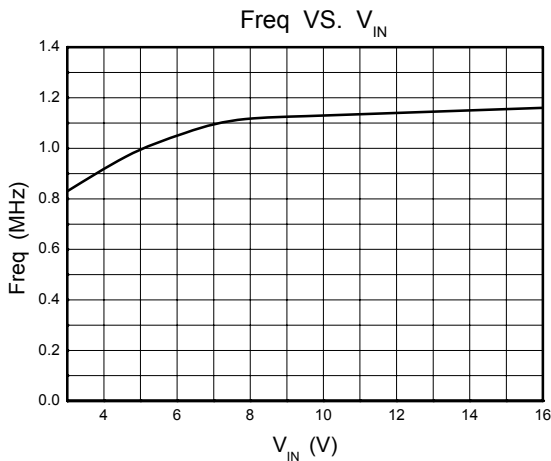
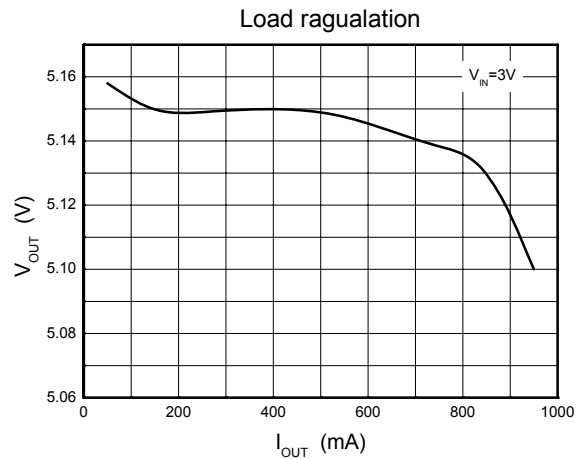
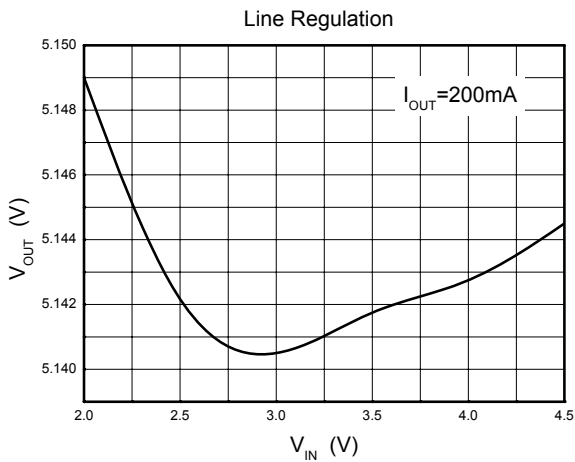
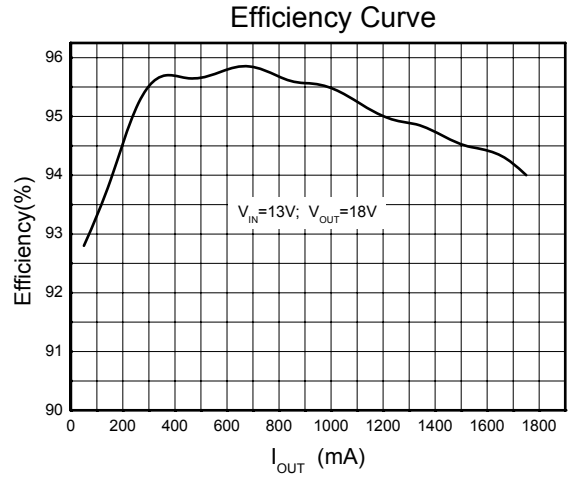
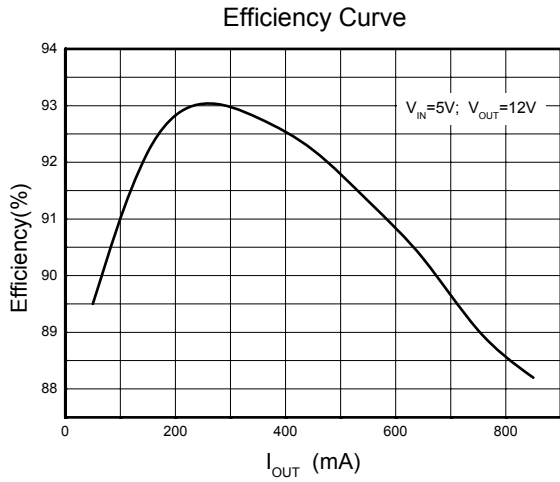

Figure 3: Functional Block Diagram

● TYPICAL OPERATING CHARACTERISTICS



● OPERATION

The FS1503 uses a fixed frequency, peak current mode boost regulator architecture to regulate voltage at the feedback pin. The operation of the FS1503 can be understood by referring to the block diagram of Figure 3. At the start of each oscillator cycle the MOSFET is turned on through the control circuitry. To prevent sub-harmonic oscillations at duty cycles greater than 50 percent, a stabilizing ramp is added to the output of the current sense amplifier and the result is fed into the negative input of the PWM comparator. When this voltage equals the output voltage of the error amplifier the power MOSFET is turned off. The voltage at the output of the error amplifier is an amplified version of the difference between the 0.6V bandgap reference voltage and the feedback voltage. In this way the peak current level keeps the output in regulation. If the feedback voltage starts to drop, the output of the error amplifier increases. This results in more current to flow through the power MOSFET, thus increasing the power delivered to the output. The FS1503 has internal soft start to limit the amount of input current at startup and to also limit the amount of overshoot on the output.

● APPLICATION INFORMATION

Setting the Output Voltage

The internal reference V_{REF} is 0.6V (Typical). The output voltage is divided by a resistor divider, R_1 and R_2 to the FB pin. The output voltage is given by

$$V_{OUT} = V_{REF} \times \left(1 + \frac{R_1}{R_2}\right)$$

● Inductor Selection

The recommended values of inductor are 4.7 to 22 μ H. Small size and better efficiency are the major concerns for portable device, such as FS1503 used for mobile phone. The inductor should have low core loss at 1.2MHz and low DCR for better efficiency. To avoid inductor saturation current rating should be considered.

● Capacitor Selection

Input and output ceramic capacitors of 22 μ F are recommended for FS1503 applications. For better voltage filtering, ceramic capacitors with low ESR are recommended. X5R and X7R types are suitable because of their wider voltage and temperature ranges.

● Diode Selection

Schottky diode is a good choice for FS1503 because of its low forward voltage drop and fast reverse recovery. Using Schottky diode can get better efficiency. The high speed rectification is also a good characteristic of Schottky diode for high switching frequency. Current rating of the diode must meet the root mean square of the peak current and output average current multiplication as following :

$$I_D (RMS) \approx \sqrt{I_{OUT} \times I_{PEAK}}$$

The diode's reverse breakdown voltage should be larger than the output voltage.

● Layout Consideration

For best performance of the FS1503, the following guidelines must be strictly followed.

Input and Output capacitors should be placed close to the IC and connected to ground plane to reduce noise coupling.

The GND should be connected to a strong ground plane for heat sinking and noise protection.

Keep the main current traces as possible as short and wide.

SW node of DC-DC converter is with high frequency voltage swing. It should be kept at a small area.

Place the feedback components as close as possible to the IC and keep away from the noisy devices.

- Package Information

SOT-23-6L PACKAGE OUTLINE DIMENSIONS

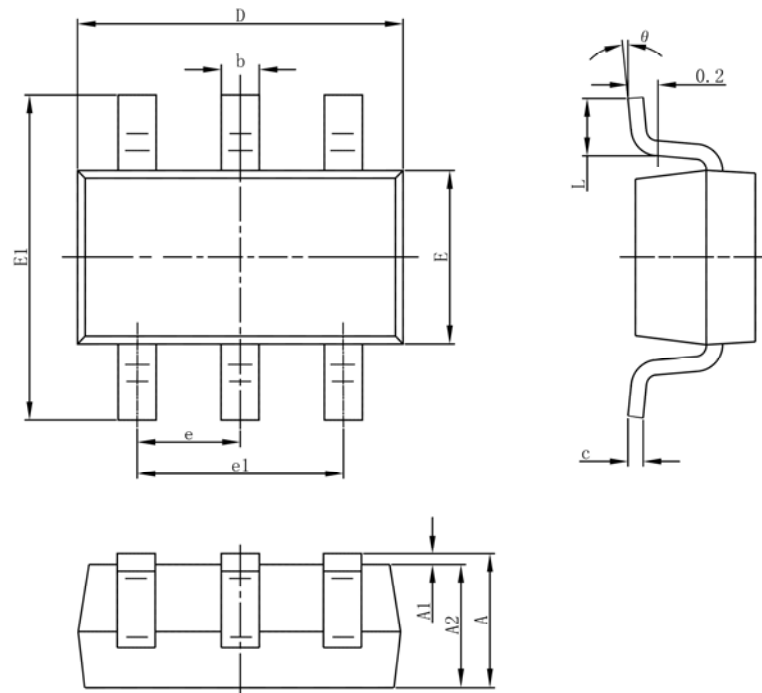

Symbol	Dimensions In Millimeters		Dimensions In Inches	
	Min	Max	Min	Max
A	1.050	1.250	0.041	0.049
A1	0.000	0.100	0.000	0.004
A2	1.050	1.150	0.041	0.045
b	0.300	0.500	0.012	0.020
c	0.100	0.200	0.004	0.008
D	2.820	3.020	0.111	0.119
E	1.500	1.700	0.059	0.067
E1	2.650	2.950	0.104	0.116
e	0.950(BSC)		0.037(BSC)	
e1	1.800	2.000	0.071	0.079
L	0.300	0.600	0.012	0.024
theta	0°	8°	0°	8°