

300KHz PFM Control Step-Up DC/DC Converter

● Features

- Low voltage operation: Startup at 0.9 V @ $I_{OUT} = 1$ mA
- Working frequency: 300KHz
- External parts: Coil, capacitor, diode
- Accuracy of $\pm 2\%$
- High efficiency 87%typ.
- Shutdown function
- Low ripple, Low noise

● Applications

- Digital cameras
- Electronic notebooks and PDAs
- Portable CD/MD players
- Cameras, video equipment
- Communications equipment
- Power supply for microcomputers

● INTRODUCTION

The FS1502 is a CMOS PFM-control step-up switching DC/DC converter. The PFM controller allows the duty ratio to be automatically switched according to the load, enabling products with a low ripple over a wide range, high efficiency, and high output current. With the FS1502, a step-up switching DC/DC converter can be configured by using an external coil, capacitor, and diode.

● Typical Block Diagram

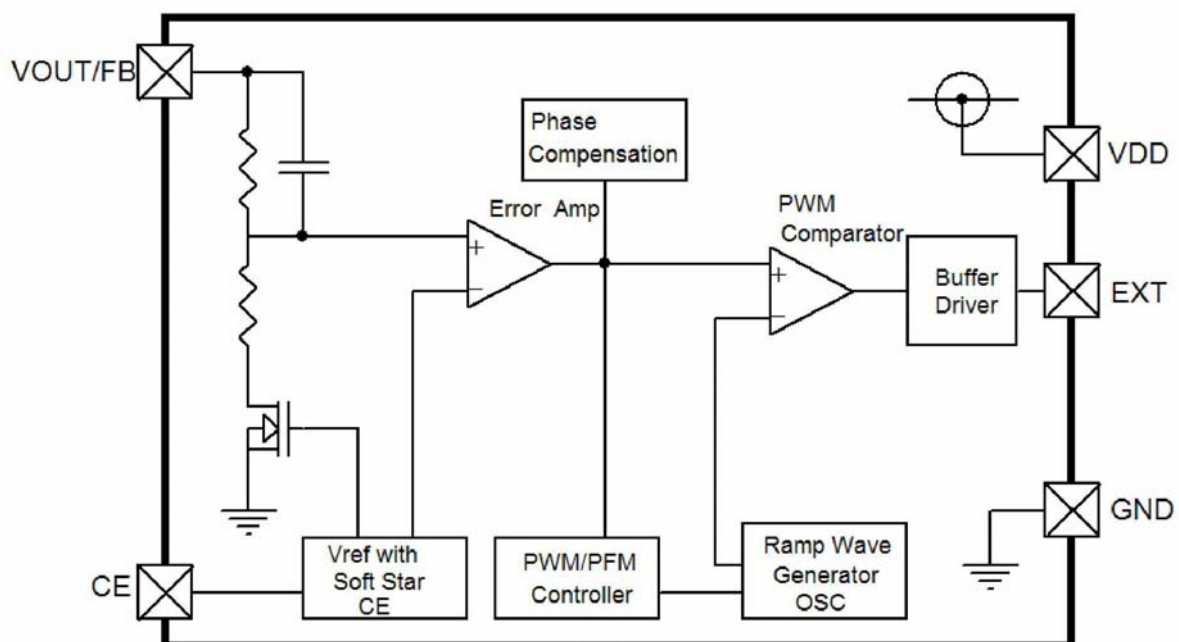

FS1502

- **Pin Configurations**

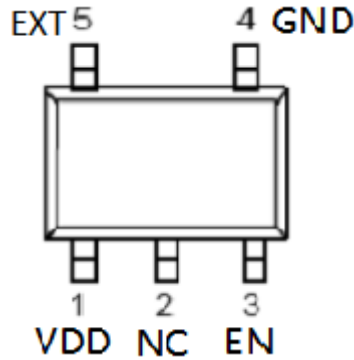

- **Pin Description**

Pin Name	Pin Description	
FS1502A		
1	VDD / V _{OUT}	Output voltage pin/ Feedback Pin
2	NC	NC
3	CE	Shutdown pin; "H": Normal operation; "L": Step-up stopped
4	GND	GND pin
5	EXT	External transistor connection pin

- **Ordering Information**

FS1502-①②③④⑤

DESIGNATOR	SYMBOL	DESCRIPTION
①		A or B
②③	Integer	Output Voltage e.g.: 3.0V=②:3; ③:0 ADJ=②:A; ③:D
④⑤	SK	Package: SOT-23-5

- **Absolute Maximum Ratings** (Unless otherwise specified, T_a= 25°C)

PARAMETER	SYMBOL	RATINGS	UNITS
V _{OUT} pin voltage	V _{OUT}	V _{SS} -0.3 ~ V _{SS} +8	V
EN pin voltage	EN	V _{SS} -0.3 ~ V _{SS} +8	V
LX pin voltage	V _{LX}	V _{SS} -0.3 ~ V _{SS} +8	V
LX pin current	I _{LX}	1500	mA
Power, dissipation	P _D	600	mW
Operating temperature	T _{opr}	-20 ~ +85	°C
Storage temperature	T _{stg}	-40 ~ +125	°C
Soldering Temperature & Time	T _{solder}	260°C, 10s	

- **Electrical Characteristics**(Unless otherwise specified, T_a=25°C)

FS1502

PARAMETER	SYMBOL	CONDITIONS	MIN	TYP	MAX	UNITS
Output voltage	V_{OUT}	—	$V_{OUT(S)} \times 0.98$	V_{OUT}	$V_{OUT(S)} \times 1.02$	V
Input voltage	V_{IN}	—	—	—	6	V
Operation start voltage	V_{ST}	$I_{OUT} = 1 \text{ mA}$	—	—	0.9	V
Hold voltage	V_{HOLD}	$I_{OUT} = 1 \text{ mA}$	0.8	—	—	V
Current consumption	I_{SS}	$V_{OUT} = V_{OUT(S)} + 0.5 \text{ V}$	—	7	—	μA
Current consumption during shutdown	I_{SSS}	$V_{EN} = 0 \text{ V}$, No load	—	—	1.0	μA
Maximum Oscillation frequency	F_{max}	$V_{OUT} = 0.95 \times V_{OUT}$ measure waveform at LX pin	—	300	—	KHz
Duty ratio	Duty		—	75	—	%
Efficiency	EFFI		—	87	—	%
Current limit	I_{LIMIT}		—	1000	—	mA
Shutdown pin input voltage	V_{SH}		1.5	—	—	V
	V_{SL}		—	—	0.3	V
Shutdown pin input current	I_{SH}		—	—	0.1	μA
	I_{SL}		-0.1	—	—	μA

Remark $V_{IN} = V_{OUT(S)} \times 0.6$ applied, $I_{OUT} = V_{OUT(S)} / 250$

$V_{OUT(S)}$ specified above is the set output voltage value, and V_{OUT} is the typical value of the actual output voltage.

FS1502

STANDARD CIRCUITS

Component: Inductor 22 μ H(Sumida),Capacitor47 μ F/10V(Tantalum),DiodeIN5817/IN5819,NMOS FS2102 FS4468

1、 Fixed output voltage

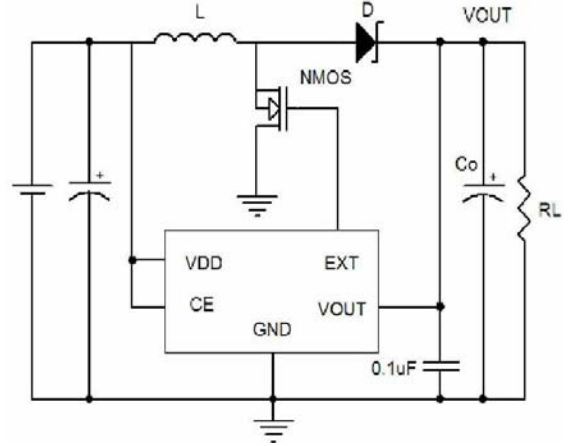
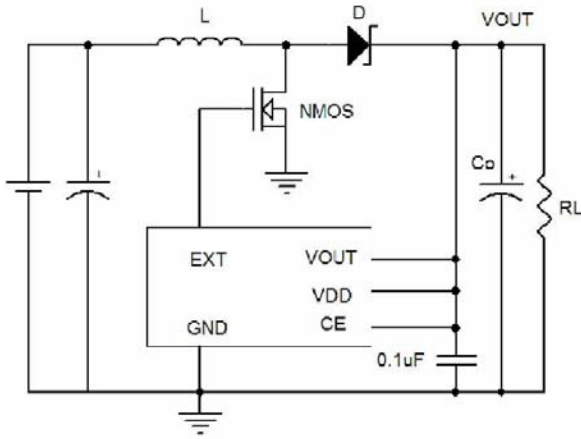

PERFORMANCE CHARACTERISTICS

FS1502-50SK

V_{OUT} VS. I_{OUT}

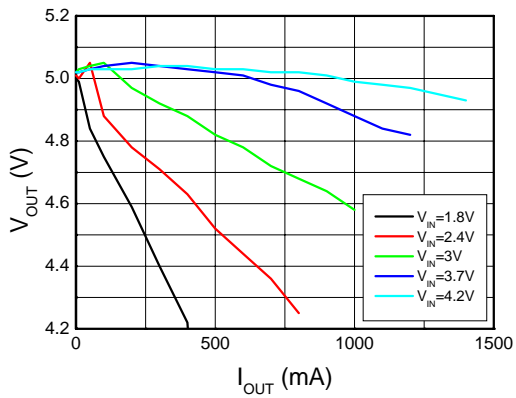

EFFICIENCY VS. I_{OUT}

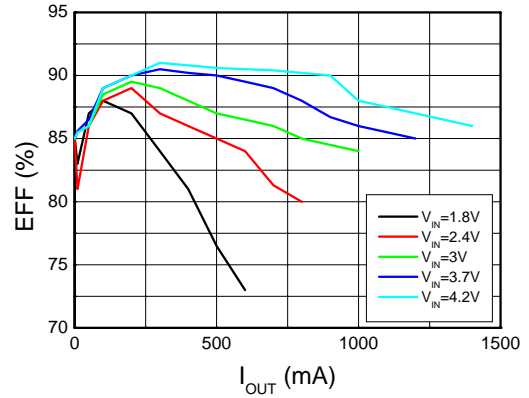

FS1502

- PACKAGE INFORMATION

SOT-23-5

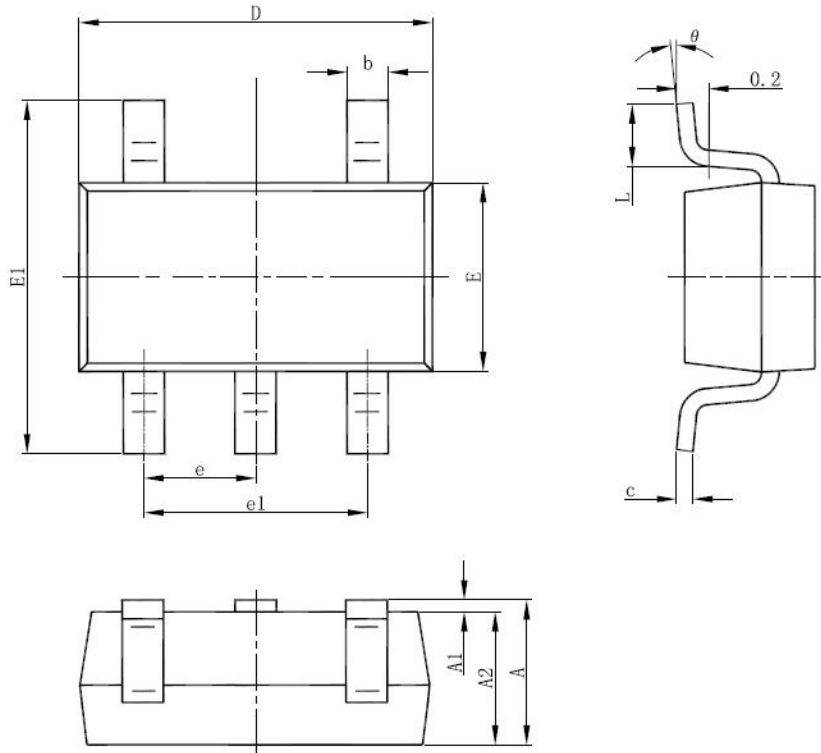

Symbol	Dimensions In Millimeters		Dimensions In Inches	
	Min	Max	Min	Max
A	1.050	1.250	0.041	0.049
A1	0.000	0.100	0.000	0.004
A2	1.050	1.150	0.041	0.045
b	0.300	0.500	0.012	0.020
c	0.100	0.200	0.004	0.008
D	2.820	3.020	0.111	0.119
E	1.500	1.700	0.059	0.067
E1	2.650	2.950	0.104	0.116
e	0.950(BSC)		0.037(BSC)	
e1	1.800	2.000	0.071	0.079
L	0.300	0.600	0.012	0.024
θ	0°	8°	0°	8°