

MicroPower Regulated Charge Pump

● Features

- Step-Up Voltage Converter
- Input Voltage Range: 2.7 to 5.0V
- MicroPower Consumption: 60 μ A
- Fixed 5V, 4.5V \pm 4% Output
- Peak Current 250mA for 100ms
- High Frequency 750kHz Operation
- Logic-Controlled Shutdown
- Short-Circuit/Over-Temperature Protection
- Lead (Pb) Free SOT23-6 Package

● Applications

- Cellular Phones
- Digital Cameras
- Handheld Electronics
- LED/Display Backlight Driver
- LEDs for Camera Flash Portable
- Communication Devices
- MP3 Players
- GPS Receivers
- PDAs

● General Description

The FS1310 is a MicroPower switched capacitor voltage converter that delivers a regulated output. No external inductor is required for operation. The FS1310 can deliver up to 100mA to the voltage regulated output. It features very low quiescent current and high efficiency over a large portion of its load range, making this device ideal for battery-powered applications. Furthermore, the combination of few external components and small package size keeps the total converter board area to a minimum in space-restricted applications.

The FS1310 uses a pulse skipping technique to provide a regulated output from a varying input supply. The FS1310 contains a thermal management circuit to protect the device under continuous output short-circuit conditions. The FS1310 has lead (Pb) free SOT23-6 package and is rated over the -40° C to +85° C temperature range.

● Pin Configurations

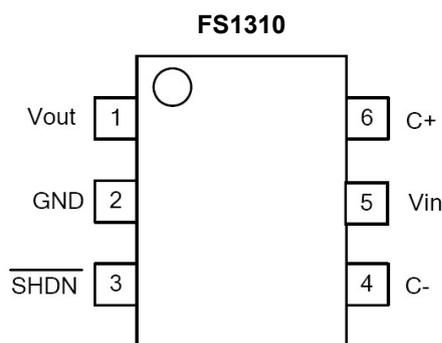

● Typical Application

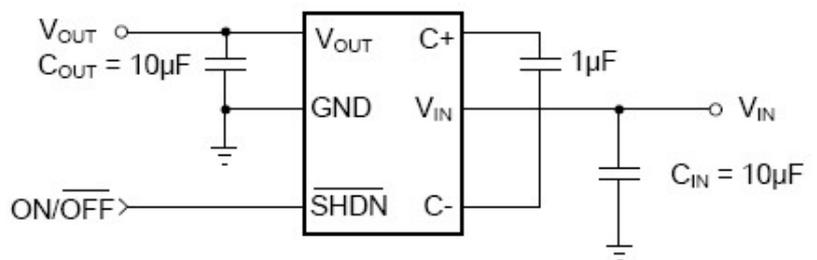

● Package/Ordering Information

Order Number	Package Description	Package Option	Marking Information
FS1310-5.0SL	SOT23-6	Tape and Reel, 3000	LAJ**

- **Absolute Maximum Ratings**

VIN to GND	-0.3V to 6V	Package Thermal Resistance	
Vout to GND	-0.3V to 6V	SOT23-6, θ_{JA}	250°C/W
SHDN to GND.....	-0.3V to 6V	Lead Temperature Range (Soldering 10 sec)	
Storage Temperature Range.....	-65°C to +150°C	260°C
Junction Temperature.....	160°C	ESD Susceptibility	
Operating Temperature Range	-40°C to +85°C	HBM.....	2000V
Power Dissipation, PD @ TA = 25°C		MM.....	400V
SOT23-6	0.34W		

NOTES:

Stresses above those listed under Absolute Maximum Ratings may cause permanent damage to the device. This is a stress Rating only; functional operation of the device at these or any other conditions above those indicated in the operational section of this specification is not implied. Exposure to absolute maximum rating conditions for extended periods may affect device reliability.

- **Caution**

This integrated circuit can be damaged by ESD if you don't pay attention to ESD protection. SGMICRO recommends that all integrated circuits be handled with appropriate precautions. Failure to observe proper handling and installation procedures can cause damage.

ESD damage can range from subtle performance degradation to complete device failure. Precision integrated circuits may be more susceptible to damage because very small parametric changes could cause the device not to meet its published specifications.

- **Pin Description**

Name	Function
VOUT	Regulated output pin.
GND	Ground
SHDN	Shutdown input. Logic low signal disables the converter.
C-	Flying capacitor negative terminal.
VIN	Input supply pin.
C+	Flying capacitor positive terminal.

FS1310

● Electrical Characteristics

(TA = -40°C to +85°C, unless otherwise noted. Typical values are at TA = 25°C, CFLY = 1μF, CIN = 10μF, COUT = 10μF).

Parameter	Symbol	Conditions	Min	Typ	Max	Units
FS1310-5.0						
Input Voltage Range	V _{IN}	V _{OUT} = 5.0V	2.7		V _{OUT}	V
Output Voltage	V _{OUT}	2.7V < V _{IN} < 5V, I _{OUT} ≤ 50mA	4.8	5.0	5.2	V
		3.0V < V _{IN} < 5V, I _{OUT} ≤ 100mA	4.8	5.0	5.2	
Quiescent Power Supply Current	I _Q	2.7V < V _{IN} < 5V, I _{OUT} = 0mA, SHDN= V _{IN}		60	68	μA
Shutdown Supply Current	I _{SHDN}	2.7V < V _{IN} < 3.6V, I _{OUT} = 0mA, V _{SHDN} = 0		0.2	1	μA
		3.6V < V _{IN} < 5V, I _{OUT} = 0mA, V _{SHDN} = 0			1	
Ripple Voltage	V _{RIPPLE}	V _{IN} = 2.7V, I _{OUT} = 50mA		15		mVP-P
		V _{IN} = 3V, I _{OUT} = 100mA		88		
Efficiency	η	V _{IN} = 2.7V, I _{OUT} = 50mA		91		%
Frequency	f _{OSC}	Oscillator Free Running		750		kHz
SHDN Input Threshold High	V _{IH}		1.4			V
SHDN Input Threshold Low	V _{IL}				0.4	
SHDN Input High Current	I _{IH}	SHDN= V _{IN}	-1		+1	μA
SHDN Input Low Current	I _{IL}	SHDN = GND	-1		+1	μA
Turn-On Time	T _{ON}	V _{IN} = 3V, I _{OUT} = 0mA		0.3		ms
FS1310-4.5						
Input Voltage Range	V _{IN}	V _{OUT} = 4.5V	2.7		V _{OUT}	V
Output Voltage	V _{OUT}	2.7V < V _{IN} < 4.5V, I _{OUT} ≤ 50mA	4.32	4.5	4.68	V
		3.0V < V _{IN} < 4.5V, I _{OUT} ≤ 100mA	4.32	4.5	4.68	
Quiescent Power Supply Current	I _Q	2.7V < V _{IN} < 4.5V, I _{OUT} 0mA, SHDN= V _{IN}		60	68	μA
Shutdown Supply Current	I _{SHDN}	2.7V < V _{IN} < 3.6V, I _{OUT} = 0mA, V _{SHDN} = 0		0.2	1	μA
		3.6V < V _{IN} < 4.5V, I _{OUT} = 0mA, V _{SHDN} = 0			1	
Ripple Voltage	V _{RIPPLE}	V _{IN} = 2.7V, I _{OUT} = 50mA		15		mVP-P
		V _{IN} = 3V, I _{OUT} = 100mA		88		
Efficiency	η	V _{IN} = 2.7V, I _{OUT} = 50mA		83		%
Frequency	f _{OSC}	Oscillator Free Running		750		kHz
SHDN Input Threshold High	V _{IH}		1.4			V
SHDN Input Threshold Low	V _{IL}				0.4	
SHDN Input High Current	I _{IH}	SHDN= V _{IN}	-1		+1	μA
SHDN Input Low Current	I _{IL}	SHDN = GND	-1		+1	μA
Turn-On Time	T _{ON}	V _{IN} = 3V, I _{OUT} = 0mA		0.3		ms

Specifications subject to changes without notice.

FS1310

● Typical Performance Characteristics

At $V_S = +5.0V$, $T_A = +25^\circ C$, $V_{IN} = 3V$, $C_{IN} = C_{OUT} = 10\mu F$, $C_{FLY} = 1\mu F$, unless otherwise noted.

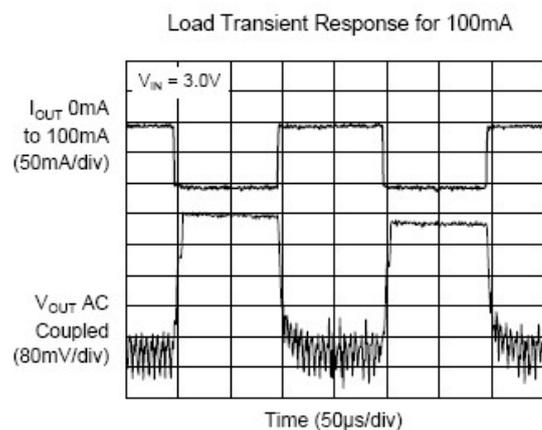
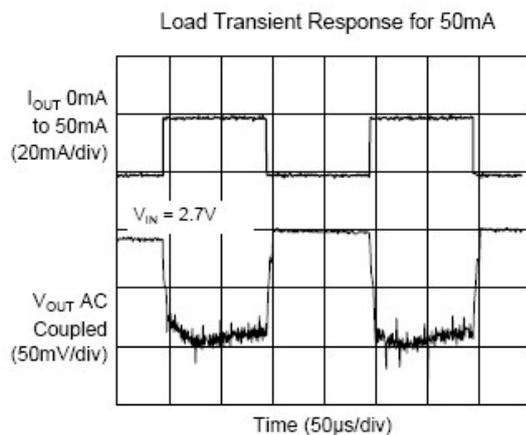
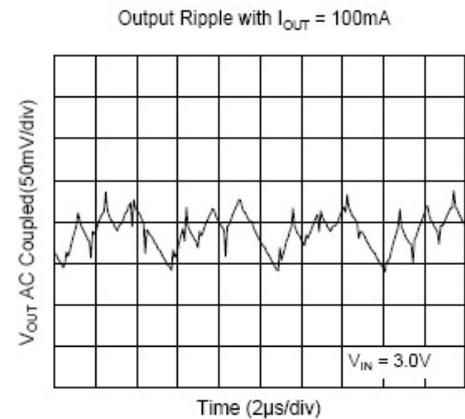
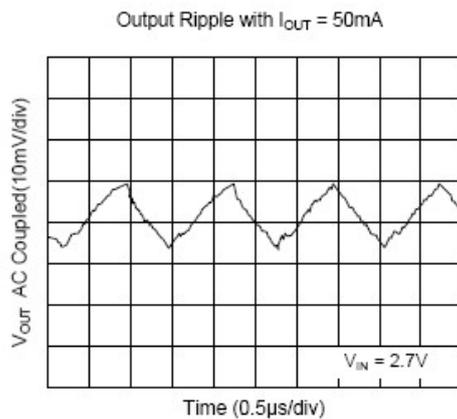
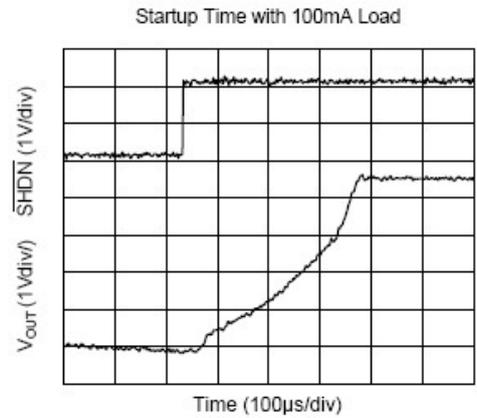
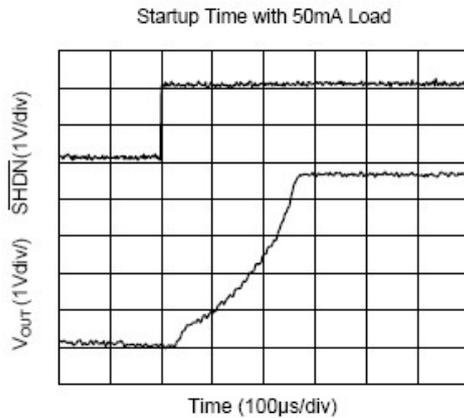

FS1310

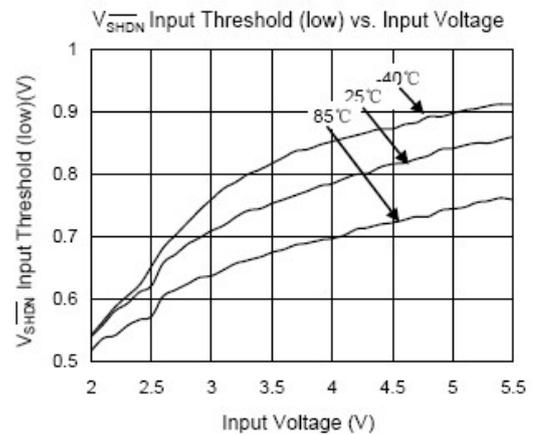
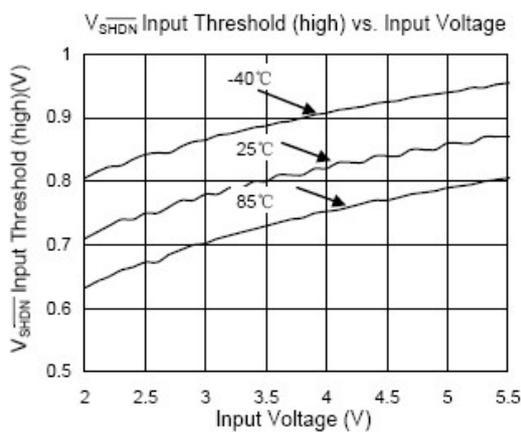
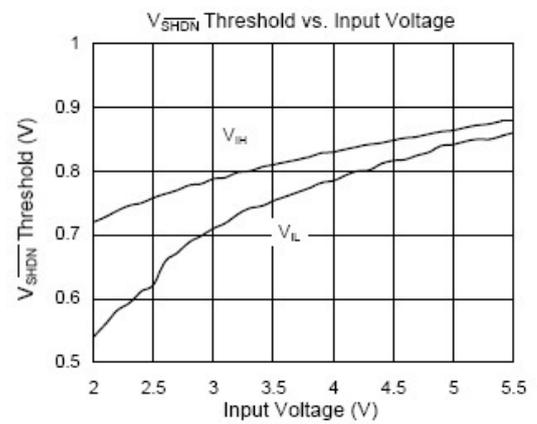
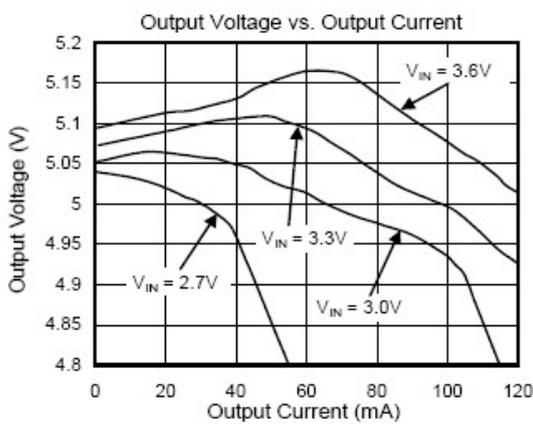
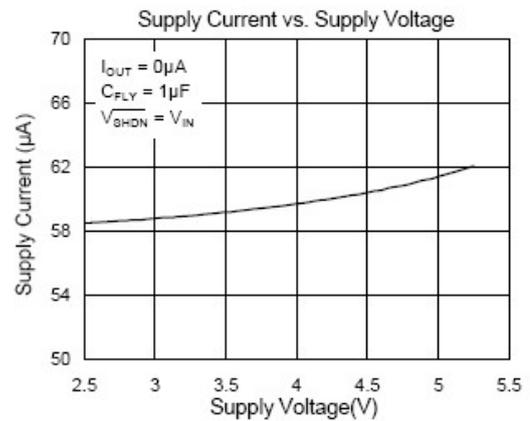
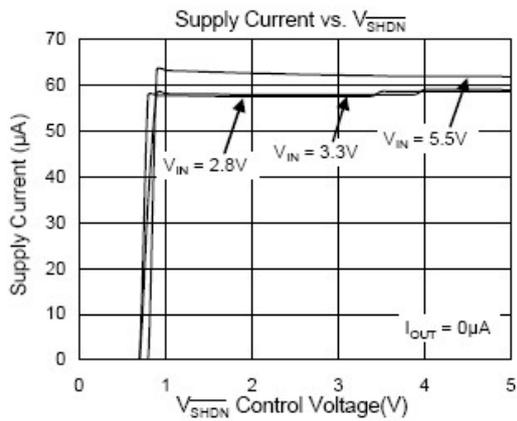

FS1310

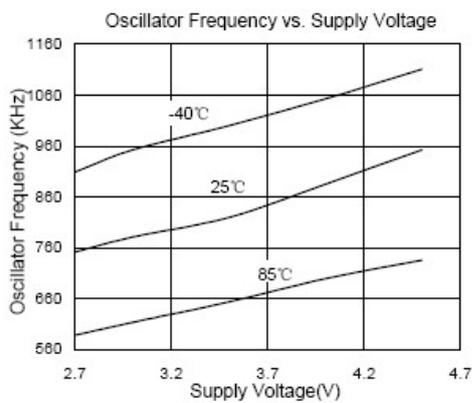
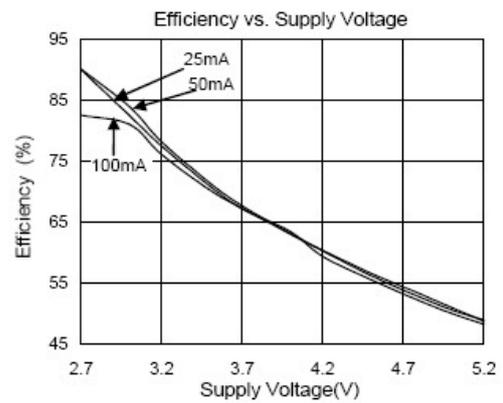
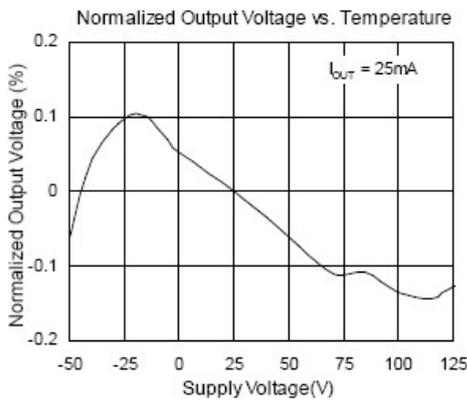

- Package Information

SOT23-6

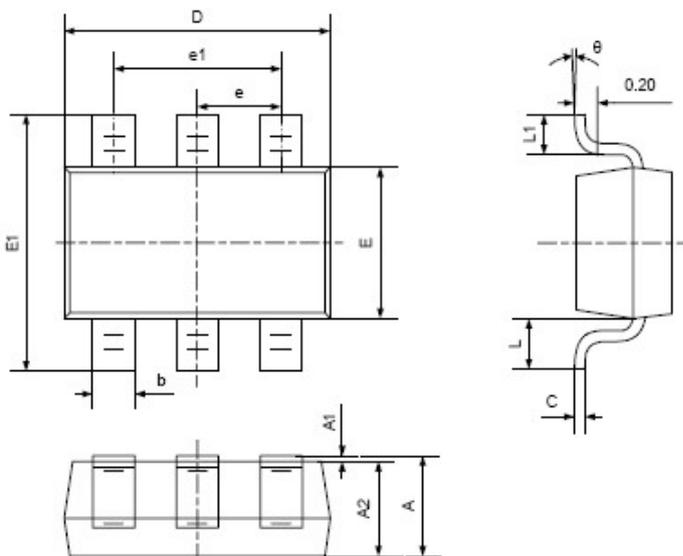

Symbol	Dimensions In Millimeters		Dimensions In Inches	
	Min	Max	Min	Max
A	1.050	1.250	0.041	0.049
A1	0.000	0.100	0.000	0.004
A2	1.050	1.150	0.041	0.045
b	0.300	0.400	0.012	0.016
C	0.100	0.200	0.004	0.008
D	2.820	3.020	0.111	0.119
E	1.500	1.700	0.059	0.067
E1	2.650	2.950	0.104	0.116
e	0.950TYP		0.037TYP	
e1	1.800	2.000	0.071	0.079
L	0.700REF		0.028REF	
L1	0.300	0.600	0.012	0.024
θ	0°	8°	0°	8°